

JpGU-AGU JOINT MEETING 2026

24 – 29 MAY
CHIBA, JAPAN

TRANSFORMATIVE SCIENCE
FOR LIFE & EARTH



Exhibition Guidance

- Publishers Desk-
- University Panel-
- Science Society Desk-



Japan Geoscience Union

1. Outline of JpGU-AGU Joint Meeting 2026

Name of the meeting	JpGU-AGU Joint Meeting 2026
Dates	Sunday, May 24 – Friday, May 29, 2026
Meeting format	Hybrid (In-person and Online)
On-site venue	International Conference Hall & International Exhibition Hall 7-8 Makuhari Messe, Chiba City
Host	Japan Geoscience Union American Geophysical Union

Society Members

Japanese Society for Biological Sciences in Space	Japan Society of Earth Science Education
Japan Society of Engineering Geology	THE ASSOCIATION FOR THE GEOLOGICAL COLLABORATION IN JAPAN
The Japanese Society of Hot Spring Sciences	Japanese Association of Groundwater Hydrology
The Oceanographic Society of Japan	The Geochemical Society of Japan
The Volcanological Society of Japan	PALEO10: Paleosciences Society
Japan Association for Wind Engineering	Society of Geomagnetism and Earth, Planetary and Space Sciences (SGEPSS)
Japanese Society for Active Fault Studies	Japanese Geomorphological Union
Meteorological Society of Japan	The Geological Society of Japan
Japan Association of Mineralogical Sciences	Japan Cartographers Association
The Palaeontological Society of Japan	THE GEOTHERMAL RESEARCH SOCIETY OF JAPAN
The Japanese Association for Arid Land Studies	The Japanese Society for Geographical Science
The Society of Resource Geology	Geographical Association of Japan
The Seismological Society of Japan	The Geographic Education Society of Japan
Japan Society for Natural Disaster Science	Geographic Information System Association of Japan
Japan Society of Geoinformatics	Tokyo Geographical Society
Japanese Association of Hydrologic of Science	The Tohoku Geographical Association
Japan Society of Hydrology & Water Resources	Japanese Society of Soil Physics
Society of Eco-Engineering, SEE	The Clay Science Society of Japan
Japanese Society for Origins of Life and Astrobiology	The Society of Agricultural Meteorology of Japan
The Japanese Association for Petroleum Technology	The Society of Exploration Geophysicists of Japan
The Japanese Society of Snow and Ice	Japan Society of Mountain Science
The Geodetic Society of Japan	The Japanese Association of Organic Geochemists (JAOG)
The Japan Society of Atmospheric Chemistry	The Japanese Society of Physical Hydrology
Society of Atmospheric Electricity of Japan	The Remote Sensing of Society Japan
The Sedimentological Society of Japan	The Japanese Society for Planetary Sciences
Japan Association for Quaternary Research	

Co-sponsor

The Astronomical Society of Japan	National Institute of Information and Communications Technology
Japan Society of Civil Engineers	Institute for Rural Engineering, NARO
Japan Association for Earthquake Engineering	National Research Institute for Earth Science and Disaster RIKEN
The Japanese Geotechnical Society	High Energy Accelerator Research Organization
Japan Society of Erosion Control Engineering	National Astronomical Observatory of Japan
The Japanese Coral Reef Society	National Institute of Polar Research
Sponsorship	Japan Geotechnical Consultants Association
Science Council of Japan	Tokyo Geotechnical Consultant Association
Ministry of Education, Culture, Sports, Science and Technology-Japan	Japan Analytical Instruments Manufacturers' Association
Geospatial Information Authority of Japan	Japan Space Forum
Kakioka Magnetic Observatory, Japan Meteorological Agency	Fukada Geological Institute
Japan Oil, Gas and Metals National Corporation	Japan Association of Surveyors
National Museum of Nature and Science	The Japan Landslide Society
Japan agency for Marine-Earth Science and Technology	Chiba Convention Bureau and International Center
National Institute for Environmental Studies, Japan	Chiba City
National Institute of Advanced Industrial Science and Technology	Chiba Prefectural Board of Education

2. Exhibit Information

1. Publishers Desk, University Panel, Science Society Desk

Dates : Sunday, MAY 24 – Friday, May 29, 2026
10:00 a.m. – 6:30 p.m.
(until 4 p.m. on the last day)

Venue : International Conference Hall
1F /2F Lobby



2F Lobby, International Conference Hall

2. Venue Map

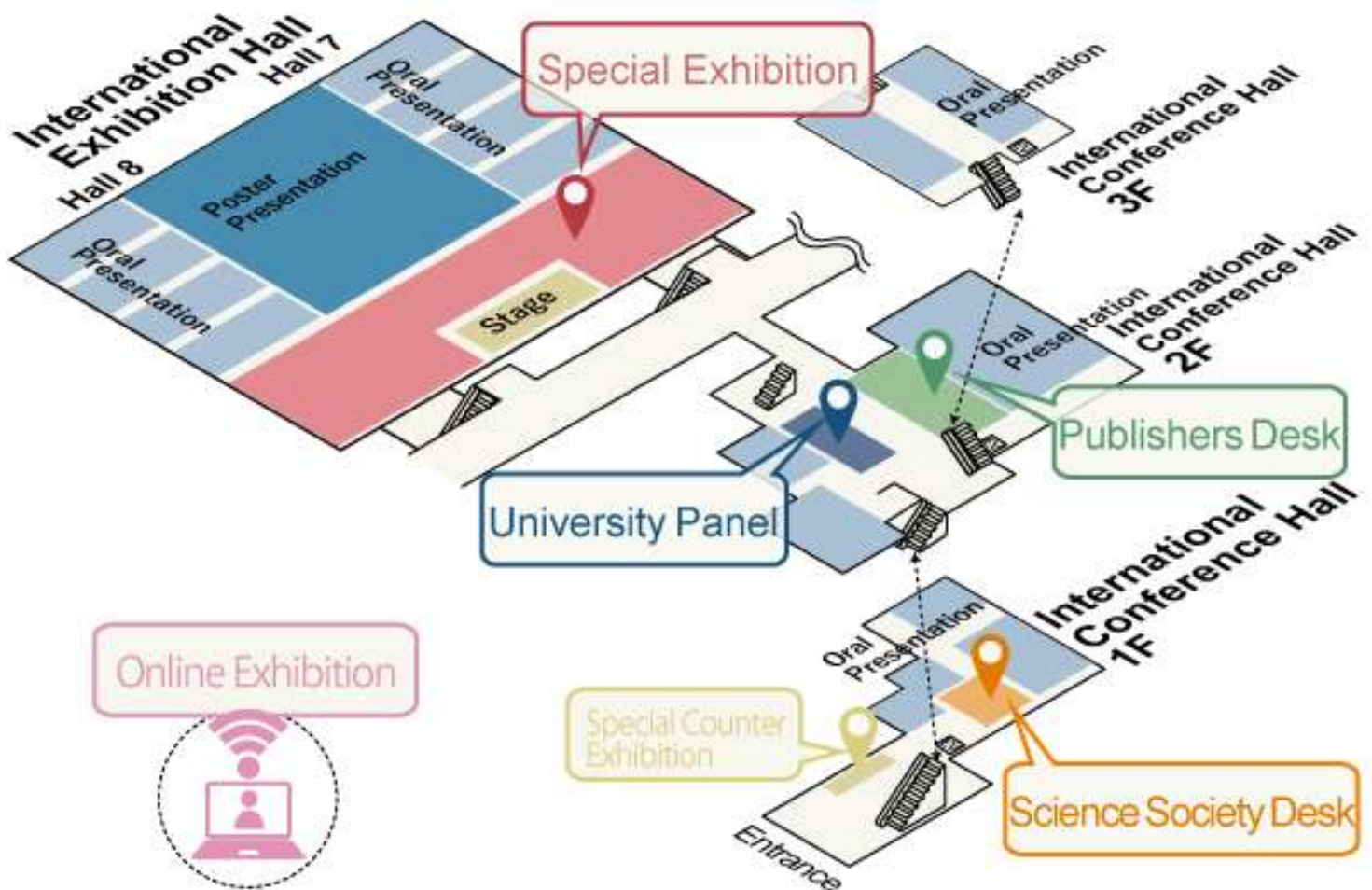

3. Schedule

International Conference Hall

University Panel, Publishers Desk, Society Desk, Special Counter Exhibition

Time	24-May	25-May	26-29-May	29-May
	The previous day	The first Day	2nd-5th day	The final day
8:00AM				
9:00		Carrying-in Installation 8:30~10:00		
10:00		Show Hours 10:00~5:00	Show Hours 10:00~4:00	
11:00				
0:00PM				
1:00				
2:00				
3:00	*No set up. Carrying-in 3:00~6:00			
4:00			Dismantling 4:00~5:30	
5:00				
6:00				
7:00				
8:00				

Session
8:30 Open
AM1 9:00~10:30
AM2 10:45~0:15
Lunch 0:15~1:45
PM1 1:45~3:15
PM2 3:30~5:00
Exhibition Hall 7-8 PM3 5:15~7:00 (On-site Poster Core Time)

4. Contact

[Details of the venue, optional items, carry-in & carry-out]
 Asakura (she/her) , Shimizu (he/him) , Makuhari Messe, Inc.
 2-1, Nakase, Mihama-ku, Chiba-city, 261-8550 Japan
 E-mail : jpgu@m-messe.co.jp

[Details of the exhibition, advertisement application and general information]
 Sugimura (he/him), Japan Geoscience Union Office
 (person in charge of the exhibitions)
 2-4-16 Yayoi, Bunkyo-ku, Tokyo, 113-0032, Japan
 Email: exhibition@jpgu.org

3. About Payment

1. Exhibition fee (tax included)

- JpGU Office will contact you separately regarding billing for sponsor.

Publishers Desk: 78,700 yen / booth (tax included)

University Panel: 94,200 yen / booth (tax included)

**Science Society Desk: Society member 40,000 yen / booth (tax included)
non-Society member 53,300 yen / booth (tax included)**

- This fee will be charged by Japan Geoscience Union Office.
- **Exhibition fee is invoiced after the JpGU Meeting. Invoice should be issued by the exhibitor after logging in to Registration system for exhibitors.** (JpGU Office will not send invoices directly to exhibitors.)
- Please inform JpGU Office of any special procedures.
- **Please log in from the online system below and proceed to payment.**
<https://www.jpгу-member.org/exhibition-booth2026/mypage/>
Please choose either credit card payment or bank transfer.

The bank account

SUMITOMO MITSUI BANKING CORPORATION Koishikawa Branch

Savings account:3761271 Japan Geoscience Union

Swift Code: SMBCJPJT

* Bank transfer fees are the responsibility of the exhibitor .

- As a rule, cancellations will not be accepted after the application has been received. In case of unavoidable circumstances, please contact the secretariat.
- In case of cancellation, a cancellation fee will be charged :
 - 50% of the exhibition fee for cancellations up to March 31.
 - 100% for cancellations on and after April 1.

2. Fees for optional items

*Please apply for optional items through the Registration system for exhibitor by April 24.

- Makuhari Messe, Inc. will invoice each exhibitor after the JpGU Meeting . (Overseas exhibitors will be invoiced in advance.)
- In addition to the total amount of optional items, an administration fee of 10% will be charged.
- A quotation will be issued upon request.
- Makuhari Messe, Inc. will send the bank account information to each exhibitor.

4. Floor Plan, Exhibitor List

【2F Lobby】

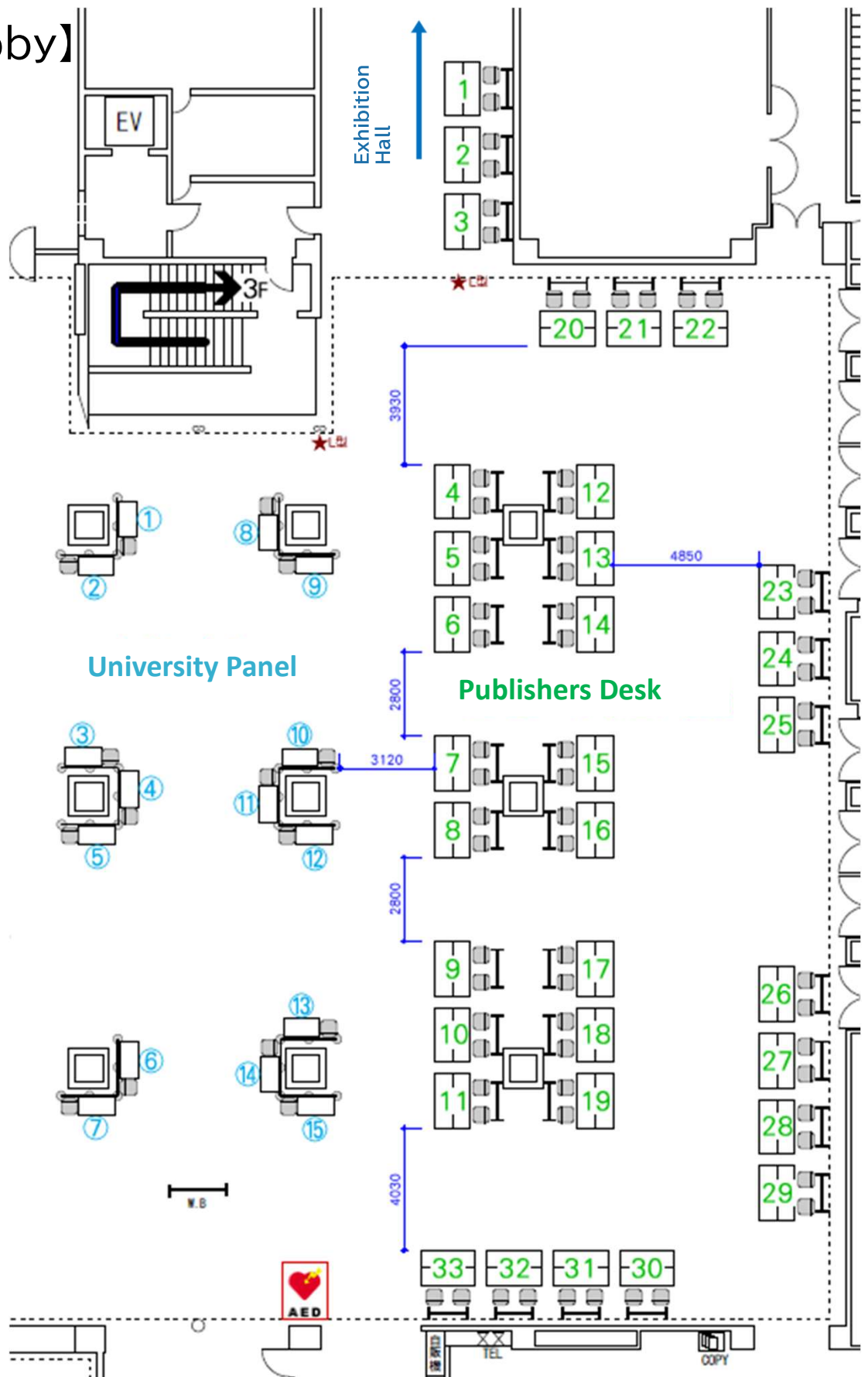

No.	University Panel / Exhibitor
Univ01-Univ02	The International Joint Graduate Program in Earth and Environmental Sciences, Tohoku University
Univ03	Tohoku University SyDE WISE Program
Univ06	Earth and Planetary Systems Science Program, Graduate School of Advanced Science and Engineering, Hiroshima University
Univ07	Center for Data Assimilation Research and Applications
Univ08	Department of Earth and Planetary Sciences, Faculty of Science, Hokkaido University
Univ09	Earth and Environmental Sciences, Graduate School of Environmental Studies, Nagoya University
Univ10	ARC-Space / Univ. Aizu: Aizu Research Center for Space Informatics
Univ11	Earthquake Research Institute, The University of Tokyo
Univ12	Planetary Exploration Research Center, Chiba Institute of Technology
Univ13	Department of Earth and Space Science, The University of Osaka
Univ14	Institute of Low Temperature Science, Hokkaido University

No.	Publishers Desk / Exhibitor
Pub02	KURUMIYA accessories inspired by natural science
Pub03	GeoGashi Outreach Team
Pub04	RC GEAR
Pub05	Sairisha
Pub06	Accel Kitchen
Pub07	Ikegami GeoResearch
Pub08	Overleaf / Writefull
Pub09	University of Tokyo Press
Pub10	ASAKURA Publishing co Ltd
Pub11	Kokon Shoin
Pub16	The Geological Society of London
Pub19	MDPI
Pub20-Pub22	NICHIKA Inc.
Pub26	Springer Nature
Pub30-Pub31	Neutrino Tokyo Inc.
Pub33	KYORITSU SHUPPAN CO., LTD.

*This lists are as of April 2, 2026.

【1F Lobby】

No.	Science Society Desk Exhibitor
Soc01- Soc02	The Oceanographic Society of Japan
Soc03	Japanese Geomorphological Union (JGU)
Soc04	The Society of Exploration Geophysicists of Japan (SEGJ)
Soc05	Goechemical Society of Japan
Soc06	Society of Geomagnetism and Earth, Planetary and Space Sciences (SGEPSS)
Soc07	Palaeontological Society of Japan
Soc08	The Volcanological Society of Japan
Soc09	The Remote Sensing Society of Japan
Soc10	Japan Association of Mineralogical Sciences
Soc11	The Geological Society of Japan
Soc12	The Geodetic Society of Japan

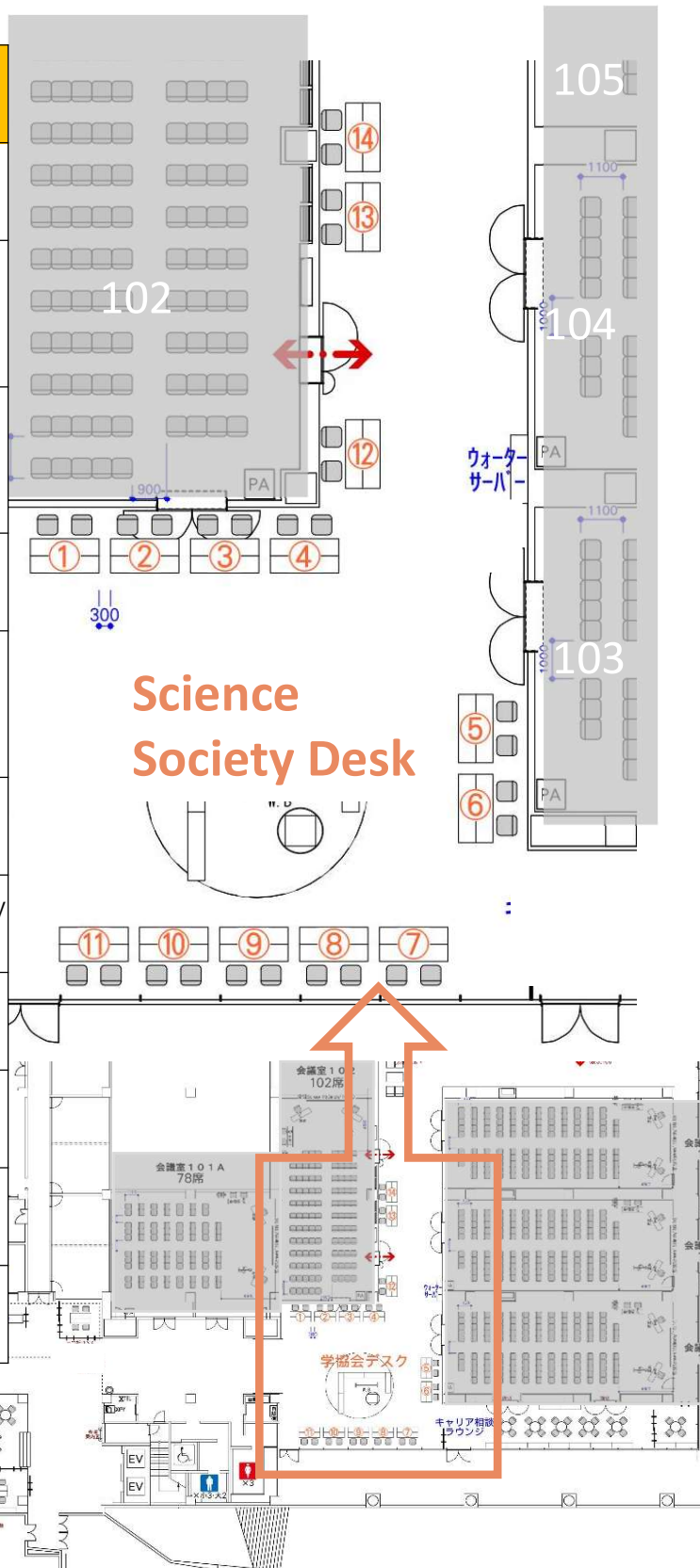

Science Society Desk

*Due to the circumstances of the venue, we are unable to set up the day before for Soc05 and 06. For details, please contact the venue setup staff.

*This list is as of April 2, 2026.

↓ To Kaihim-makuhari Sta.

5. Booth Plan

【Publisher Desk】

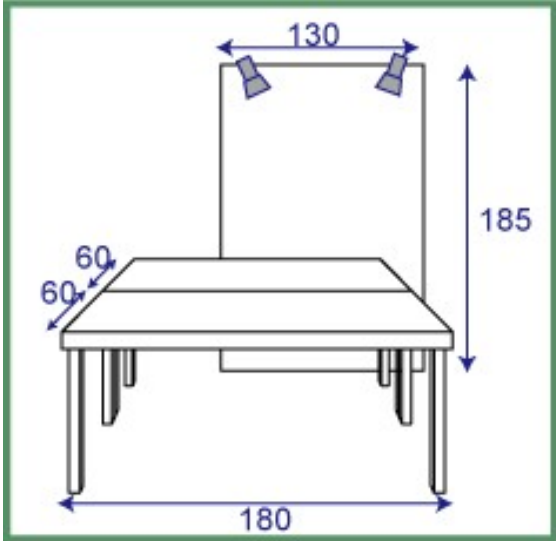
Applicable to	Publishers, proofreaders/translators, book and related products dealers, etc.	
Exhibition fee	78,700yen (tax included)/booth	
Booth size	Exhibition space: 1800 x 1200 (mm)	
Included in the exhibition fee	<ol style="list-style-type: none"> 1) Table x 2 (W1800 x D600 x H700) 2) Cloth (white) x 2 3) Chair x 2 4) Board and Rights 	
Exhibitor Pass to be provided	<ol style="list-style-type: none"> a. Exhibitor Pass B x 2 (Entry to the exhibition area only during the entire exhibition period) b. Online Meeting Pass x 2 	
Booth details		
	Name plate	W420 x H300
	Floor surface	Carpeted
	Table	W1800 x D600 x H700 x 2 Cloth (white) x 2
Others	<ul style="list-style-type: none"> ➤ Please select items other than the above basic specifications from the list of optional items. ➤ Power supply is not available. It is an optional item. ➤ The basic specifications will be installed by the JpGU Office prior to exhibitor's set-up. 	

【University Panel】

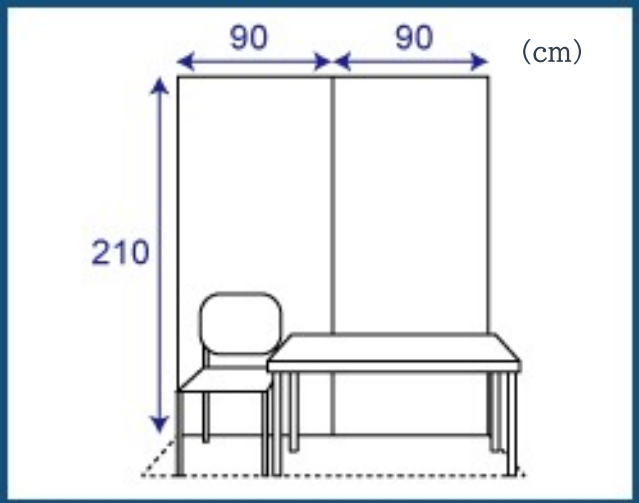
Applicable to	University, Graduate School, etc.	
Exhibition fee	94,200 yen (tax included) /booth	
Booth Size	W1800×D600×H2100 (mm)	
Included in the exhibition fee	(1) One set of back panel (W1800 x H2100) (2) One company name plate x 1 (W420 x H300) (3) Table x 1 (W1200 x D600 x H700) (4) Cloth (white) x 1 (5) Chair x 1	
Exhibitor Pass to be provided	a. Exhibitor Pass A x 1 *Entitles the exhibitor to enter all area, including the lecture rooms, throughout the entire Meeting period, in the same way as general attendees. b. Exhibitor Pass B x 2 *Entry to the exhibition area only c. Online Meeting Pass x 3	
Booth Details		
	Name Board size	W 420 X H300
	Back Panels	Cross-lining *Please use thumbtacks for displaying posters, etc. or hooks & chains for displaying panels, etc. Hooks and chains are not provided on site, so that please bring your own ones.
	Floor surface	Carpeted
	Table	W1200 x D600 x H700 x 1
Others	<ul style="list-style-type: none"> ➤ Please select items other than the above basic specifications from the list of optional items. ➤ Power supply is not available. It is an optional item. ➤ Basic specifications will be installed by the JpGU Office and delivered to exhibitors. 	

【Science Society Desk】

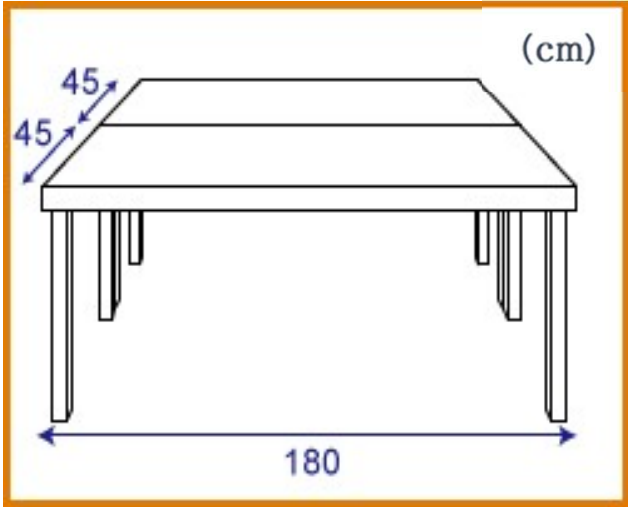
Applicable to	Academic Societies, Associations, etc.	
Exhibition fee	Society members: 40,000 yen (tax included) / booth Non-society members: 53,300 yen (tax included) / booth	
Booth Size	W1800 x D900 (mm)	
Included in the exhibition fee	(1) Table x 2 (W1800 × D450 × H700) (2) Cloth (white) x 2 (3) Chair x 2	
Exhibitor Pass to be provided	a. Exhibitor Pass B x 2 *Entry to the exhibition area only a. Online Meeting Pass x 2	
Booth Details		
	Name Board size	W420*H300 (mm)
	Floor surface	Carpeted
	Table	W1800 x D450 x H700 x 2 Cloth (white) x 2
Others	<ul style="list-style-type: none"> ➤ Please select items other than the above basic specifications from the list of optional items. ➤ Power supply is one of optional items. ➤ The basic specifications will be installed by the JpGU Office prior to exhibitor's set-up. 	

6. Optional Items

【Publishers Desk, University Panel, Science Society Desk】

List of Optional Items

A 10% administration fee will be charged separately.

*Please apply through the Registration system for exhibitors by April 24.

Power Supply



300W (single-phase 100V 50 Hz, with two outlet socket X 1)
5,500 Yen (tax included)

- The outlet shape provided by the venue is the normal A type. If you need a shape other than this, please bring your own conversion connector.
- If you need 3-phase or 200V power, please contact Makuhari Messe.

Arm Light



*Fixed between booth panels, etc.
3,300 yen (tax included)
 *Power consumption: 20W

Catalog Stand (Tabletop)

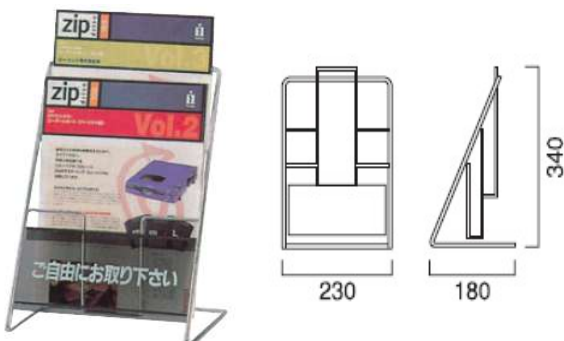

W230 x H340 x D180
3,300 yen (tax included)
 *Supports A4 vertical

Catalog stands (floor-standing)

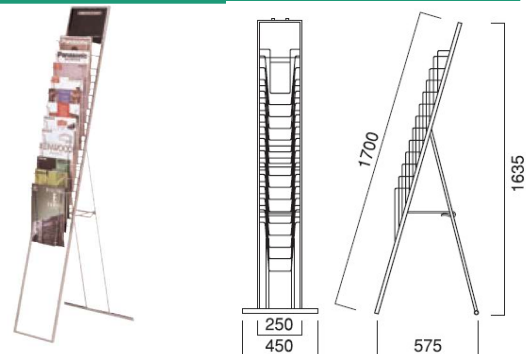

W250 x H1635 x D575
6,600 yen (tax included)
 *Supports A4 vertical

Panel Stand 1

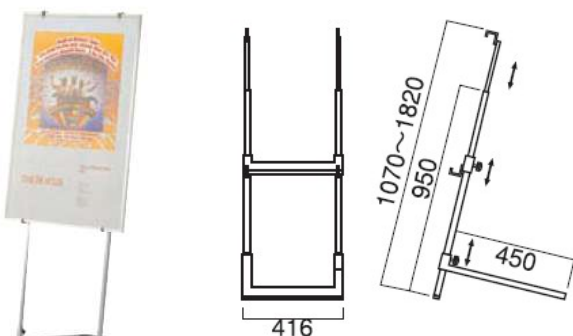

W416 x H1070-1820 x D450
8,800 yen (tax included)
 *Panels are not included.

Panel Stand 2

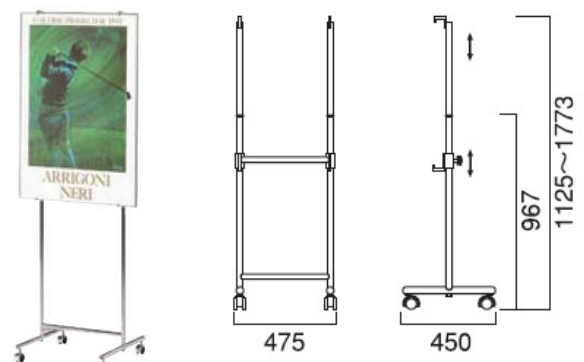

W475 x H1125-1773 x D450
7,700 yen (tax included)
 *Panel is not included.

Poster Board

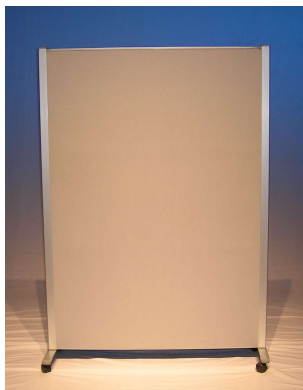

W1300×H1850,

drawing studs
can be used

*not available to
the university
panel are.

¥5,500
(tax included)

Internet Line

High-Speed Fiber Optic Line
NTT FLET'S Hikari Next Gigabit Line
Plan

*Supplied as a set of line, provider
(PPPoE), and router.

*Exhibitors are required to bring
your own HUB, LAN cables, etc.

*Up to approximately 1 Gbps (best-
effort type service)

110,000 yen (tax included)

Carry-in/out Vehicle Pass

If Exhibitor wish to carry in/out
vehicles, please apply in advance
for the desired number of Carry-
in/out Vehicle Pass through the
Registration system for exhibitors.
The Vehicle Pass will be sent in
PDF format.

Free of charge

7. Venue Service

1. Internet Service

(1) Free Wi-Fi at the International Conference Hall

- Free Wi-Fi is available at the International Conference Center.
SSID: MESSE-WiFi / PWD: makuhari26
Connection may be difficult depending on capacity, number of users, individual PC settings and functions, and location.
- Please note that users are responsible for their own anti-virus and security settings.
- Individual support for connection will not be provided.
- Since the entire hall is shared with Meeting attendees, it may be difficult to connect due to the number of users, individual device settings and functions, and other factors. Internet service may be interrupted without prior notice for certain reasons.
- If you need a dedicated connection for your exhibit booth, it is offered as an optional item.

(2) Free Wi-Fi at Makuhari Messe Exhibition Hall

- How to connect
 - ① Activate the Wi-Fi function on your Wi-Fi-enabled device.
 - ② Select "Messe_Free_Wi-Fi" from the list of available SSIDs and connect.
 - ③ When you stand up the browser, the top screen for users will appear.
 - ④ Please confirm the Terms of Use and register your e-mail address.
- Supported Languages Japanese, English, Chinese, Korean
- Time limit : Use Messe_Free_Wi-Fi for 30 minutes per use.
(There is no limit to the number of times you can use it per day.)
- After exceeding the limit, the top screen for users will be displayed again.

2. Personalized workboxes

- Workboxes with excellent soundproofing and sound insulation are located in the central mall on the 2nd floor.
- Please refer to the website of each URL for more details
Central Entrance: <https://waim-group.co.jp/chatbox/>
In front of Exhibition Hall 8: <https://telecube.jp/location/makuharimesse/>

3. Mobile battery stand

- Rental mobile batteries are available.
- For detailed information, please refer to the website. <https://chargespot.jp/>

4. Restaurant and Convenience store

① WORLD KITCHENS!

- Cafeteria where you can enjoy world cuisines *Non-smoking
- Location 2F Central Mall,
in front of Exhibition Hall 6

*Please confirm the date and time of operation at the site on the day of the event.

② New Yamazaki Dairy Store

- Location 2F Central Entrance
- * Please confirm the date and time of operation at the site on the day of the event.

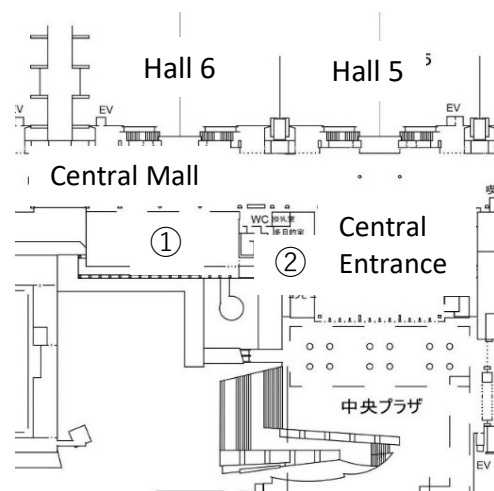

*For venue services, please refer to the Makuhari Messe Web site.

<https://www.m-messe.co.jp/facility/>

8. Carry-in

1. Carry-in time and date

- On the day before the exhibition and the first day of the exhibition, you can bring in and set up your booth during the following hours.
- Day before the exhibition: Saturday, May 23, 3:00 p.m.- 6:00 p.m.
*carry-in only, no set-up
- First day of the exhibition: Sunday, May 24, 8:30 a.m. - 10:00 a.m.

Please let JpGU Office know how to bring in your booth by May 14 (Thu.) through the registration system for exhibitors.

2. Exhibitor Pass

- Please be sure to wear your Exhibitor Pass while you are in the venue.
- Please bring your "e-Ticket" to the 1st floor of the International Conference Hall of Makuhari Messe to have your Exhibitor Pass issued.
*How to issue an Exhibitor Pass
Exhibitors can issue and print "e-Tickets" on the Registration system for exhibitors. Please bring the printed copy to entrance of the 1st floor of the International Conference Hall to print an Exhibitor Pass.
- You cannot make your presentation using this Exhibitor Pass.

Registration system for exhibitors
Japan Geoscience Web site ⇒ Menu by visitor "Exhibitors"
⇒ For those who have already applied "Log in".
<https://www.jpgu-member.org/exhibition-booth2026/mypage/>

3. Carry-in with a vehicle

Please bring and show your Vehicle Pass applied in advance at the East Gate 2. Please follow the instruction of the venue staff.

4. Using a courier service

- Please send your items to arrive on [the afternoon of Saturday, May 23rd] or [the morning of Sunday, May 24th.]
- Please fill out the invoice according to the sample below. Also, please write the package number/total number on the invoice and on each package.
- Packages will be delivered to each booth by the courier company. If you are going to receive the packages by yourselves, please checkmark the box in the Registration system for exhibitors.

【Sample invoice】

[Address]

2-1 Nakase, Mihama-ku, Chiba City
Chiba, 261-8550 Japan
Makuhari Messe
International Conference Hall,
JpGU-AGU 2026 Publishers Desk
No. 00 (Your booth number)
Exhibitor's name (as registered)
TEL: 043-296-0694 ←

[Product Name]

Name: Publishers Desk Booth No. _____.
Organization: Name of exhibitor/organization
(please fill in correctly)
No. of items/total number of items
*Example: No. 1 / Total 10 pieces

*This is the phone number of the venue.
If you wish to be present, please provide
the cell phone number of the person in charge.

*Caution

- Please keep a copy of the invoice, etc., and take care of any undelivered or lost items by yourself.
- Please do not block aisles or other spaces.
- If heavy items are to be brought into the booth, please cure the floor when necessary.

5. Sending items from overseas

- The following international shipping company is recommended. Customs clearance procedures may take some time, so please make your request as soon as possible.
- Contact:
Rock-it Cargo Japan Inc.
1-6 Nakase, Mihama-ku, Chiba-City, Chiba 261-0023
mBAY POINT Makuhari 16F
Tel: +81-43-298-4741
Mobile phone: 090-9157-2582(+81-90-9157-2582)
E-mail: taka.matsute@rockitcargo.com (Attn: Takanori Matsute)
*Please use "JpGU2026" as the subject of the e-mail.
- If you request another shipping company, please refer to the above [sample invoice] and be sure to provide details including the date and time of delivery so that you can pick up the package directly on the designated delivery date and time by yourself.
- JpGU Office and Makuhari Messe, inc. will not be able to pick up or keep your items even if it arrives before the carry-in date. The JpGU Office will not be able to handle customs clearance procedures on your behalf.

9. Dismantling

1. Date and time of dismantling

Friday, May 29, 4:00 p.m. - 6:00 p.m.

2. Using the Makuhari Messe-designated courier service

- You can use the courier service designated by Makuhari Messe (Yamato Transport, collect on delivery only, domestic shipping only).
- Yamato Transport will pickup the packages around 6:00 p.m. on Friday, May 29.
- Please fill out the necessary information on the invoice and bring the package to the pickup locations (see figure below) on May 29 (Fri.).
- The invoice will be available at Yamato Transport Desk.

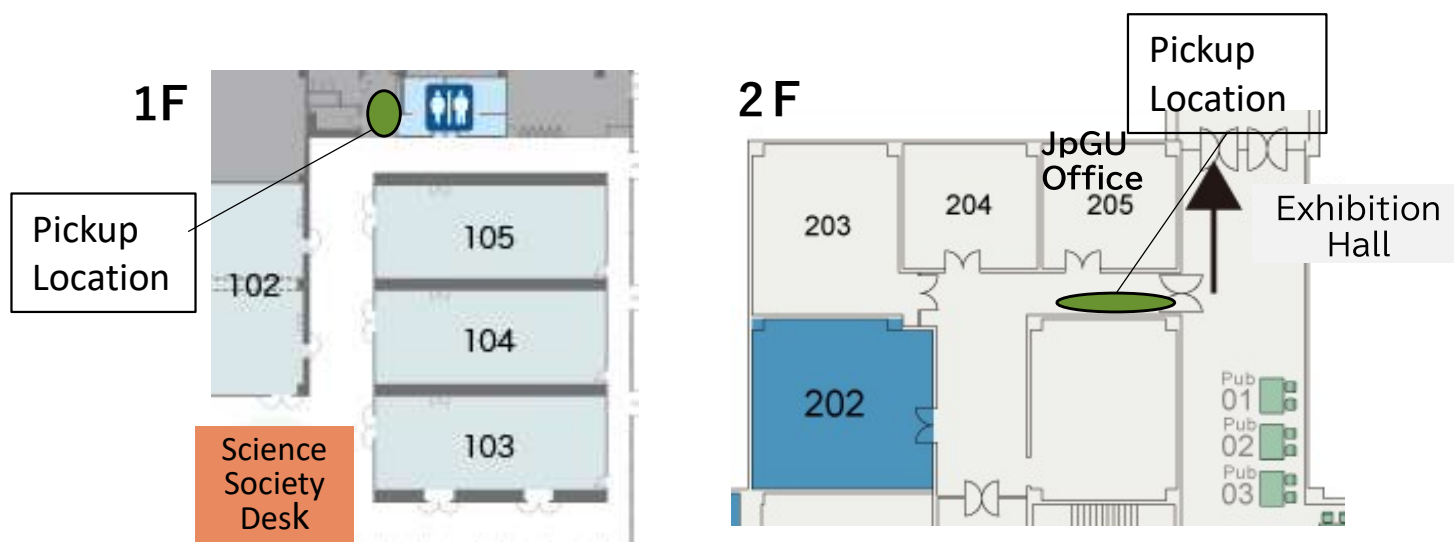

3. Making your own arrangements

- If you use other courier companies, etc., please contact them by yourself. "Carry-in/out Vehicle Pass" will be required.

4. Other requests

- Although the organizers will make every effort to ensure security from carry-in to carry-out, the JpGU Office cannot be held responsible for theft or loss of exhibits, etc. Please be careful with your items.
- Please be careful not to cause danger in the exhibition hall, as people will be moving around during poster presentations, etc.
- Please be careful not to bring out the venue items or equipment including white cloth.

10. Carrying in/out Route

1. Car Carry-in/out route

- Please enter the East Gate2 exit at the North Gate.
- At the East Gate 2, please show the "Carry-in/out Vehicle Pass" issued by the venue (Makuhari Messe) to the security guard.
- "Carry-in/out Vehicle Pass" must be applied for in advance via the Registration system for exhibitors.
- Please park your vehicle in accordance with the instructions on your vehicle pass and venue staff.
- No vehicles are allowed to enter the hall. Please carry your item with a cart, etc. from the loading exit.

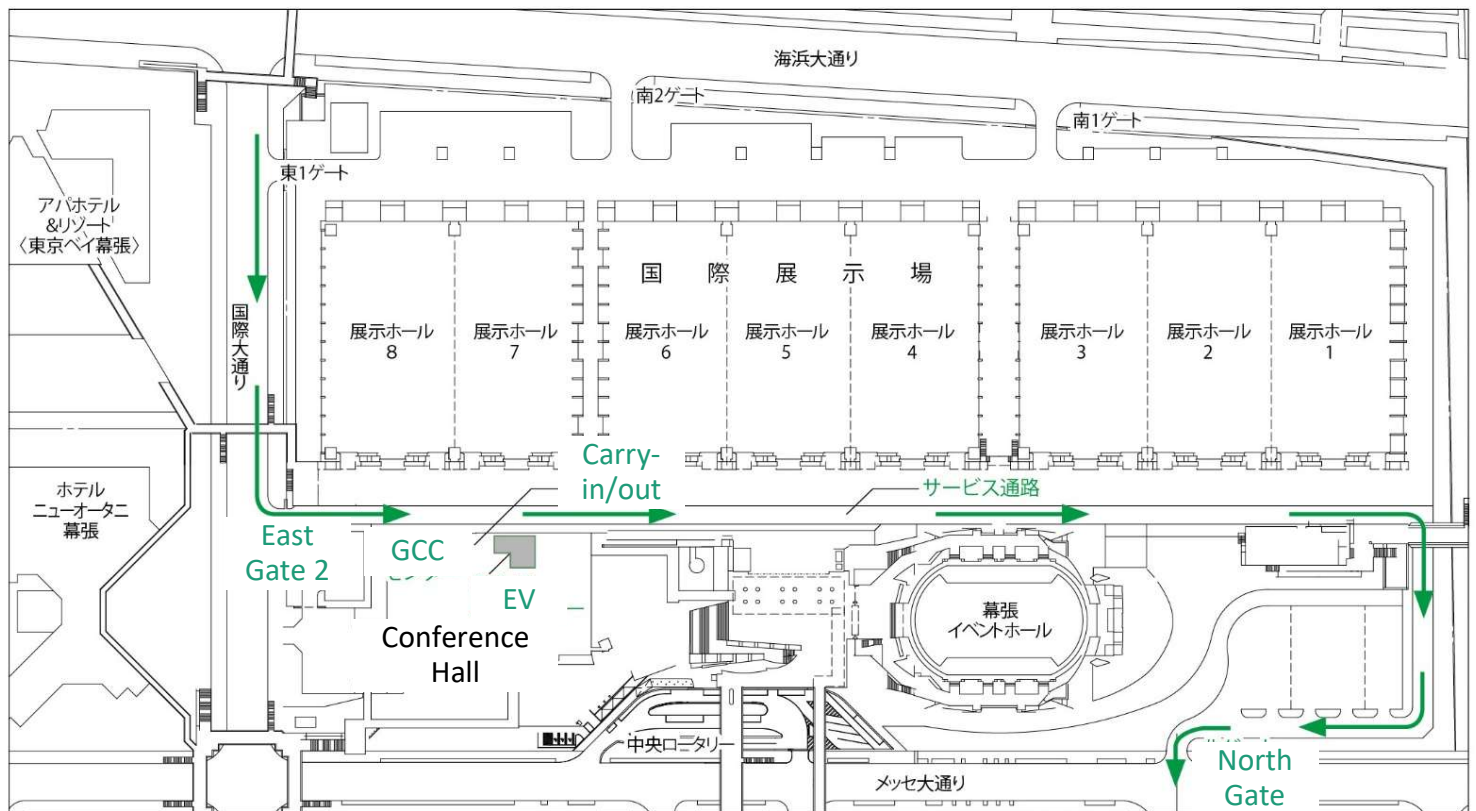

2. Carrying-in/out route in the International Conference Hall

- Please use "the service entrance" near the General Control Center for carry-in/out on the 1st floor of the International Conference Hall.
- Please use "Elevators for loading" for carry-in/out on the 2nd floor.
 - Elevator for loading (large)
: W2.35m x D5.40m x H2.40m, Loading capacity limit 3,200kg
 - Elevator for loading (small)
: W2.20m x D2.80m x H2.10m, Loading capacity limit 2,000kg
- When transporting heavy or large materials, be sure to protect the doors and carpets on each floor.

11. Precautions

Please confirm the following rules and regulations.

1. General

- The Japan Geoscience Union (JpGU) will be responsible for the overall management of the venue as the administrator, but in principle, exhibitors are responsible for managing their own belongings in your booths and exhibits. JpGU will not be held responsible for any damage, loss, or theft of exhibits.
- No storage space is provided for exhibits. If you have valuables, do not leave your booth unattended. In addition, please take necessary insurance procedures on your own.
- JpGU reserves the right to change or cancel the exhibition period due to natural disasters or other force majeure. JpGU will not compensate for any loss or damage incurred by exhibitors or related parties as a result of such changes or cancellations.
- Exhibitors are prohibited from transferring or exchanging all or part of your booths to others without JpGU's permission.
- Please confirm the designated carry-in/out times and exhibition periods. If you have any unavoidable requests, please contact the JpGU as soon as possible.
- Exhibitors whose exhibits do not meet to the event may be denied entry.

2. Setup and installation

- Direct construction (taping, nailing, scraping, attaching, etc.) on the floor, walls, etc. of the venue is strictly prohibited. Please do not damage or deface the venue, including during carry in/out.
- Ceiling structures are prohibited. The height of exhibits and decorations must be 2.1m or less. If the height is unavoidably exceeded, please consult with the secretariat in advance.
- Please contact Makuhari Messe, Inc. if there are heavy items to be exhibited. The maximum load capacity of the floor is 360kg/m² (contact Makuhari Messe, Inc. for pit areas).
- Plywood, rugs, curtains, etc. used for booth decorations must be fire-retardant. Flameproof items must be labeled with flameproof markings as stipulated in the Fire Prevention Law Enforcement Regulations.
- According to the Chiba City Fire Prevention Ordinance, smoking, the use of naked flames (including appliances with exposed heating elements), and the bringing in and use of hazardous materials are prohibited in the museum (hazardous materials: propane gas, high-pressure gas, gasoline, kerosene, petroleum, gunpowder, etc.). However, if it is unavoidable to bring in such items for demonstration of exhibits, etc., it may be allowed under certain conditions with permission from the Chiba City Fire Department.

- Exhibitors are responsible for taking all waste materials, packing materials, garbage, etc. generated during carry-in, carry-out, and exhibit. Exhibitors who leave residual materials in the venue after the event will be charged a disposal fee.
- No storage space is provided for empty boxes, packing materials, or replenishment products. Please take them home with you or use the area under the desks in your booth.
- If any problems or hazards are found in the construction or decoration of the booth, JpGU and Makuhari Messe, Inc. may request changes to be made.

3. During the exhibition period

- Construction work or exhibits that generate noise, vibration, odor, smoke, etc. that interfere with the management and operation of the venue are prohibited.
- Please adjust the volume of audio/visual equipment in your booth and the volume generated by display equipment so as not to disturb other exhibitors or attendees. If there are complaints on the day of the event, the use of the equipment may be discontinued. *Excessive volume may interfere not only with other exhibitors, but also with simultaneous broadcasts in the event of an emergency or with the operation of the conference.
- It is prohibited to conduct PR activities, etc. in areas beyond the exhibitor's booth, or to place exhibitor's equipment or items in areas other than the exhibitor's booth.
- When it is recognized that there is some obstacle or danger to the operation of the meeting, JpGU and Makuhari Messe, Inc. may ask the exhibitor to make changes to the booth.