



Japan Geoscience Union Meeting 2025

25 - 30 MAY 2025

On-site : MAKUHARI MESSE, Chiba, Japan
Online : all over the WORLD

For a Borderless World of Geoscience 

Exhibition Guidance

- Publishers Desk-
- University Panel-
- Science Society Desk-



Japan Geoscience Union

1. Outline of JpGU Meeting 2025

Outline

| | |
|---------------------|---|
| Name of the meeting | Japan Geoscience Union Meeting 2025 |
| Dates | Sunday, MAY 25 – Friday, May 30, 2025 |
| Meeting format | Hybrid (In-person and online) |
| On-site venue | International Conference Hall & International Exhibition Hall 7-8 Makuhari Messe, Chiba City |
| Host | Japan Geoscience Union |

Society Members

Japanese Society for Biological Sciences in Space, Japan Society of Engineering Geology, The Japanese Society of Hot Spring Sciences, The Oceanographic Society of Japan, The Volcanological Society of Japan, Japanese Society for Active Fault Studies, Meteorological Society of Japan, Japan Association of Mineralogical Sciences, Japan Cartographers Association, The Palaeontological Society of Japan, The Japanese Association for Arid Land Studies, The Society of Resource Geology, The Seismological Society of Japan, Japan Society of Geoinformatics, Japanese Association of Hydrologic of Science, Japan Society of Hydrology & Water Resources, Society of Eco-Engineering, SEE, The Society for the Study of the Origin and Evolution of Life: Astrobiology-Japan, The Japanese Association for Petroleum Technology, The Japanese Society of Snow and Ice, The Geodetic Society of Japan, The Japan Society of Atmospheric Chemistry, The Sedimentological Society of Japan, Japan Association for Quaternary Research, Japan Society of Earth Science Education, THE ASSOCIATION FOR THE GEOLOGICAL COLLABORATION IN JAPAN, Japanese Association of Groundwater Hydrology, The Geochemical Society of Japan, Society of Geomagnetism and Earth, Planetary and Space Sciences (SGEPSS), Japanese Geomorphological Union, The Geological Society of Japan, THE GEOTHERMAL RESEARCH SOCIETY OF JAPAN, The Japanese Society for Geographical Science, The Association of Japanese Geographers, The Geographic Education Society of Japan, Geographic Information System Association of Japan, Tokyo Geographical Society, The Tohoku Geographical Association, Japanese Society of Soil Physics, The Clay Science Society of Japan, The Society of Agricultural Meteorology of Japan, The Society of Exploration Geophysicists of Japan, The Japanese Society of Physical Hydrology, The Remote Sensing of Society Japan, The Japanese Society for Planetary Sciences, PALEO10: Paleosciences Society, Society of Atmospheric Electricity of Japan, Japan Society for Natural Disaster Science, The Japanese Association of Organic Geochemists, Japan Society of Mountain Science,

Supporting members

Regional city Convention attraction Promotion Council, FORTE Science Communication, ASO UNESCO GLOBAL GEOPARK, Crimson Interactive Japan, SOU Global & Communication Inc, Japan Geopark Network, American Journal Experts, CACTUS COMMUNICATIONS K.K., Chiba Convention Bureau and International Center, TECH OCEAN, Edanz Inc.

Co-sponsor

The Astronomical Society of Japan, Japan Society of Civil Engineers, Japan Association for Earthquake Engineering, The Japanese Geotechnical Society, Japan Society of Erosion Control Engineering, The Japan Society of High Pressure Science and Technology, The Japanese Coral Reef Society

Sponsorship

Science Council of Japan, Ministry of Education, Culture, Sports, Science and Technology-Japan, Geospatial Information Authority of Japan, Meteorological Research Institute, Kakioka Magnetic Observatory, Japan Meteorological Agency, Japan Oil, Gas and Metals National Corporation, National Museum of Nature and Science, National Institute for Environmental Studies, Japan, National Institute of Advanced Industrial Science and Technology, National Institute of Information and Communications Technology, Institute for Rural Engineering, NARO, National Institute for Materials Science, RIKEN, High Energy Accelerator Research Organization, National Astronomical Observatory of Japan, National Institute of Polar Research, Japan Geotechnical Consultants Association, Japan Analytical Instruments Manufacturers' Association, Fukada Geological Institute, Japan Association of Surveyors, The Japan Landslide Society, Chiba City, Chiba Prefectural Board of Education

2. Exhibit Information

1. Publishers Desk, University Panel, Science Society Desk

Dates : Sunday, MAY 25 – Friday, May 30, 2025
10:00 a.m. – 6:30 p.m.
(until 4 p.m. on the last day)

Venue : International Conference Hall
1F /2F Lobby



2F Lobby, International Conference Hall

2. Venue Map

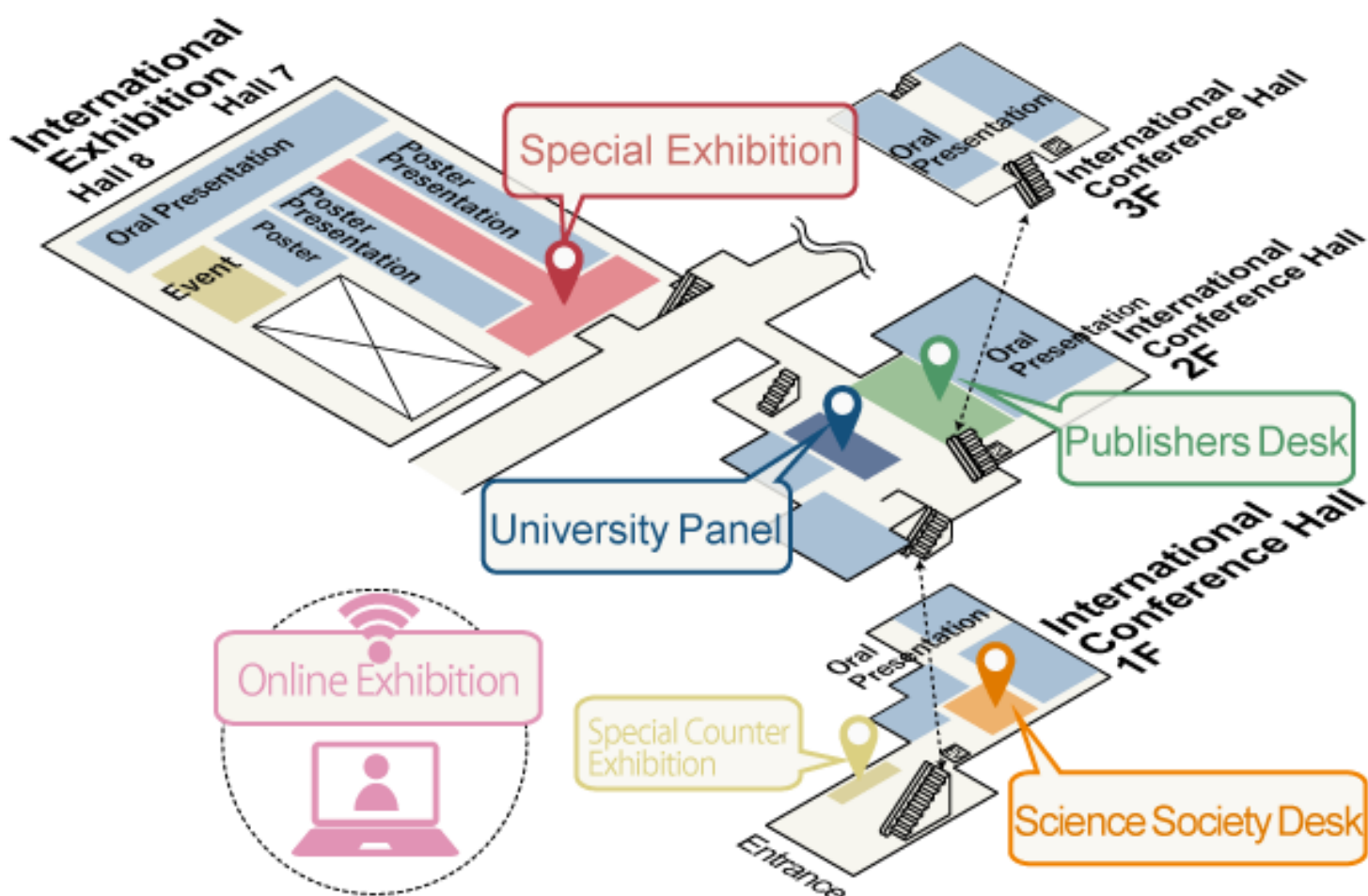

3. Schedule

International Conference Hall

University Panel, Publishers Desk, Society Desk, Special Counter Exhibition

| Time | 24-May | 25-May | 26-29-May | 30-May |
|--------|---|---|--------------------------|---------------|
| | The previous day | The first Day | 2nd-5th day | The final day |
| 8:00AM | | | | |
| 9:00 | | Carrying-in Installation 8:30~10:00 | | |
| 10:00 | | ShowHours 10:00~5:00 | ShowHours 10:00~4:00 | |
| 11:00 | | | | |
| 0:00PM | | | | |
| 1:00 | | | | |
| 2:00 | | | | |
| 3:00 | *No set up. Carrying-in 3:00~6:00 | | | |
| 4:00 | | | Dismantling 4:00~5:30 | |
| 5:00 | | | | |
| 6:00 | | | | |
| 7:00 | | | | |
| 8:00 | | | | |

| Session |
|--|
| 8:30 Open |
| AM1 9:00~10:30 |
| AM2 10:45~0:15 |
| Lunch 0:15~1:45 |
| PM1 1:45~3:15 |
| PM2 3:30~5:00 |
| Exhibition Hall 7-8 PM3 5:15~7:15 (On-site Poster Core Time) |
| |
| |

4. Contact

[Details of the venue, optional items, carry-in & carry-out]
 Matsui (she/her) , Shimizu (he/him) , Makuhari Messe, Inc.
 2-1, Nakase, Mihama-ku, Chiba-city, 261-8550 Japan
 E-mail : jpgu@m-messe.co.jp

[Details of the exhibition, advertisement application and general information]
 Sugimura (he/him), Japan Geoscience Union Office
 (person in charge of the exhibitions)
 2-4-16 Yayoi, Bunkyo-ku, Tokyo, 113-0032, Japan
 Email: exhibition@jpgu.org

3. About Payment

1. Exhibition fee (tax included)

- JpGU Office will contact you separately regarding billing for sponsor.

Publishers Desk: 60,500 yen / booth (tax included)

University Panel: 84,700 yen / booth (tax included)

**Science Society Desk: Society member 36,300 yen / booth (tax included)
non-Society member 48,400 yen / booth (tax included)**

- This fee will be charged by Japan Geoscience Union Office.
- **Exhibition fee is invoiced after the JpGU Meeting. Invoice should be issued by the exhibitor after logging in to Registration system for exhibitors.** (JpGU Office will not send invoices directly to exhibitors.)
- Please inform JpGU Office of any special procedures.
- **Please log in from the online system below and proceed to payment.**
<https://www.jpгу-member.org/exhibition-booth2025/mypage/>
Please choose either credit card payment or bank transfer.

The bank account

SUMITOMO MITSUI BANKING CORPORATION Koishikawa Branch

Savings account:3761271 Japan Geoscience Union

Swift Code: SMBCJPJT

* Bank transfer fees are the responsibility of the exhibitor .

- As a rule, cancellations will not be accepted after the application has been received. In case of unavoidable circumstances, please contact the secretariat.
- In case of cancellation, a cancellation fee will be charged :
 - 50% of the exhibition fee for cancellations up to March 31.
 - 100% for cancellations on and after April 1.

2. Fees for optional items

*Please apply for optional items through the Registration system for exhibitor by April 25.

- Makuhari Messe, Inc. will invoice each exhibitor after the JpGU Meeting . (Overseas exhibitors will be invoiced in advance.)
- In addition to the total amount of optional items, an administration fee of 10% will be charged.
- A quotation will be issued upon request. An invoice and a delivery note will be sent to all exhibitors in June.
- Payment must be made by bank transfer by July 31, 2025.
- Makuhari Messe, Inc. will send the bank account information to each exhibitor.

4. Floor Plan, Exhibitor List

【2F Lobby】

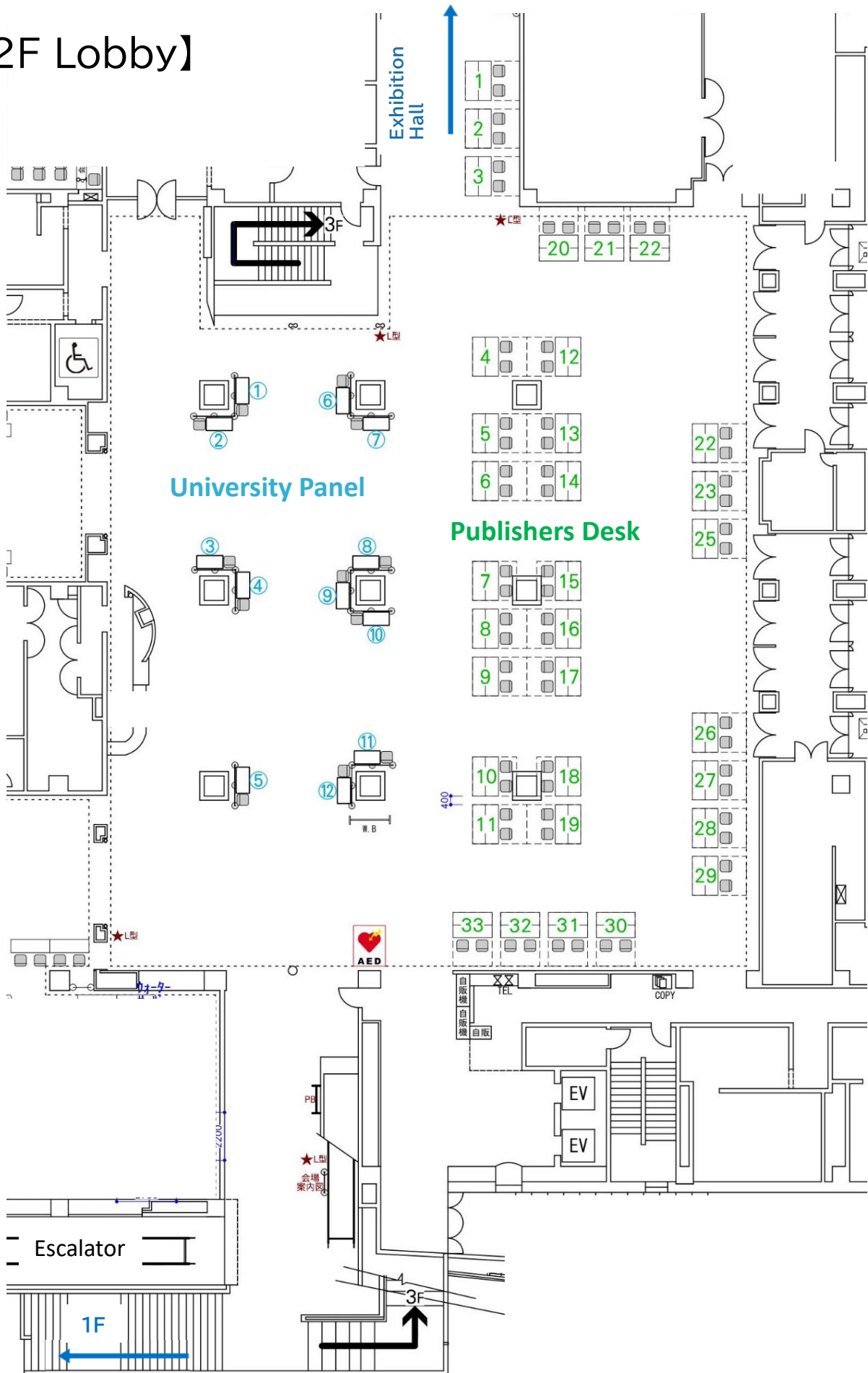

| No. | Publishers Desk / Exhibitor |
|-------|--|
| Pub01 | |
| Pub02 | KYORITSU SHUPPAN CO., LTD. |
| Pub03 | Geo T-shirt Studio |
| Pub04 | Accel Kitchen |
| Pub05 | Sairisha |
| Pub06 | Kokon Shoin |
| Pub07 | RC GEAR |
| Pub08 | Ikegami GeoResearch |
| Pub09 | Geogashi-Ryokodan |
| Pub10 | University of Tokyo Press |
| Pub11 | ASAKURA Publishing Co., Ltd. |
| Pub12 | Accel Kitchen |
| Pub13 | |
| Pub14 | |
| Pub15 | |
| Pub16 | |
| Pub17 | |
| Pub18 | |
| Pub19 | |
| Pub20 | NICHIKA INCORPORATED |
| Pub21 | NICHIKA INCORPORATED |
| Pub22 | NICHIKA INCORPORATED |
| Pub23 | Minna de Honkoku |
| Pub24 | |
| Pub25 | MDPI |
| Pub26 | Springer Nature |
| Pub27 | |
| Pub28 | |
| Pub29 | |
| Pub30 | Neutrino Tokyo Inc. |
| Pub31 | Neutrino Tokyo Inc. |
| Pub32 | |
| Pub33 | KURUMIYA accessories inspired by natural science |

| No. | University Panel / Exhibitor |
|--------|--|
| Univ01 | Departments of Geophysics and Earth Science, Tohoku University |
| Univ02 | The International Joint Graduate Program in Earth and Environmental Sciences, Tohoku University |
| Univ03 | Tohoku University WISE program for Sustainability in the Dynamic Earth |
| Univ04 | ARC-Space / Univ. Aizu: Aizu Research Center for Space Informatics |
| Univ05 | Center for Data Assimilation Research and Applications, the Institute of Statistical Mathematics |
| Univ06 | Department of Geography, Tokyo Metropolitan University |
| Univ07 | Atmosphere and Ocean Research Institute, the University of Tokyo |
| Univ08 | Department of Earth and Space Science, The University of Osaka |
| Univ09 | Earthquake Research Institute, The University of Tokyo |
| Univ10 | Planetary Exploration Research Center, Chiba Institute of Technology |
| Univ11 | Department of Earth and Planetary Sciences, Hokkaido University |
| Univ12 | Institute of Low Temperature Science, Hokkaido University |

*This lists are as of April 18, 2025.

【1F Lobby】

| No. | Exhibitor |
|-------|--|
| Soc01 | The Oceanographic Society of Japan |
| Soc02 | The Oceanographic Society of Japan |
| Soc03 | The Geological Society of Japan |
| Soc04 | The Society of Exploration Geophysicists of Japan |
| Soc05 | Goechemical Society of Japan |
| Soc06 | Society of Geomagnetism and Earth, Planetary and Space Sciences (SGEPSS) |
| Soc07 | |
| Soc08 | The Volcanological Society of Japan (VSJ) |
| Soc09 | |
| Soc10 | Japan Association of Mineralogical Sciences |
| Soc11 | Palaeontological Society of Japan |
| Soc12 | The Geodetic Society of Japan |
| Soc13 | |
| Soc14 | |

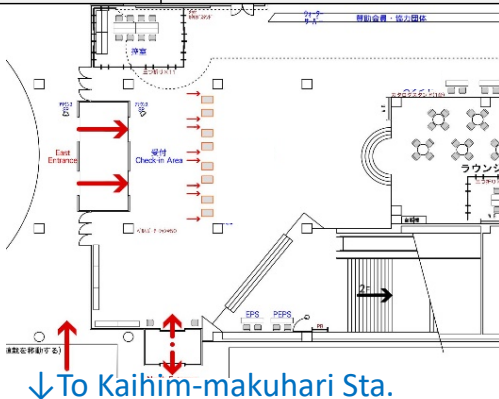
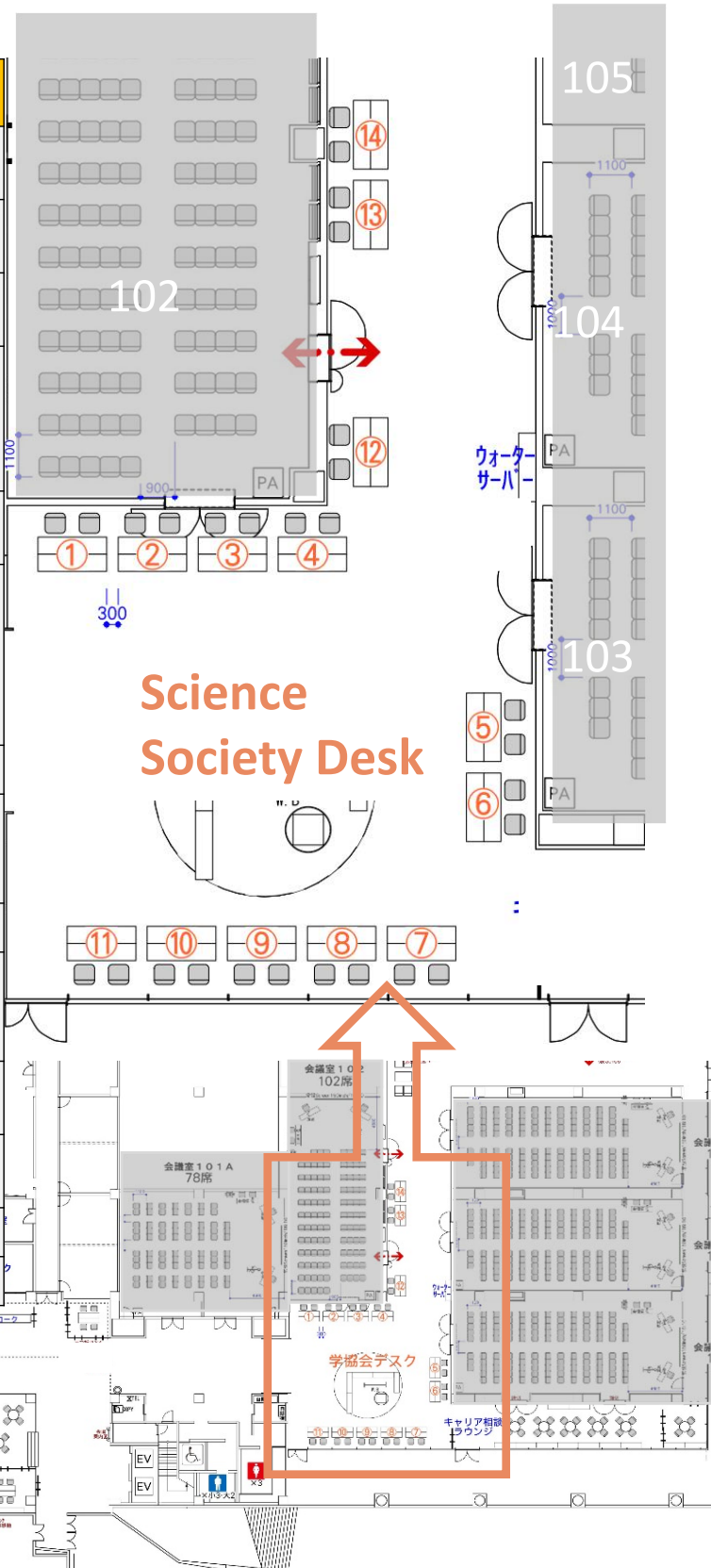

*Due to the circumstances of the venue, we are unable to set up the day before for Soc05 and 06. For details, please contact the venue setup staff.

*This list is as of April 18, 2025.

5. Booth Plan

【Publisher Desk】

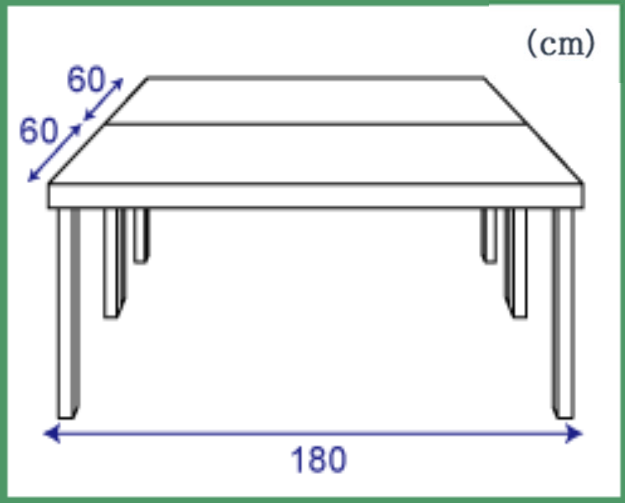
| | | |
|--------------------------------|--|--|
| Applicable to | Publishers, proofreaders/translators, book and related products dealers, etc. | |
| Exhibition fee | 60,500yen (tax included)/booth | |
| Booth size | Exhibition space: 1800 x 1200 (mm) | |
| Included in the exhibition fee | <ol style="list-style-type: none"> 1) Table x 2 (W1800 x D600 x H700) 2) Cloth (white) x 2 3) Chair x 2 | |
| Exhibitor Pass to be provided | <ol style="list-style-type: none"> a. Exhibitor Pass B x 2 (Entry to the exhibition area only during the entire exhibition period) b. Online Meeting Pass x 2 | |
| Booth details |  | |
| | Name plate | W420 x H300 |
| | Floor surface | Carpeted |
| | Table | W1800 x D600 x H700 x 2 Cloth (white) x 2 |
| Others | <ul style="list-style-type: none"> ➤ Please select items other than the above basic specifications from the list of optional items. ➤ Power supply is not available. It is an optional item. ➤ The basic specifications will be installed by the JpGU Office prior to exhibitor's set-up. ➤ There is no waiting room for exhibitors. | |

【University Panel】

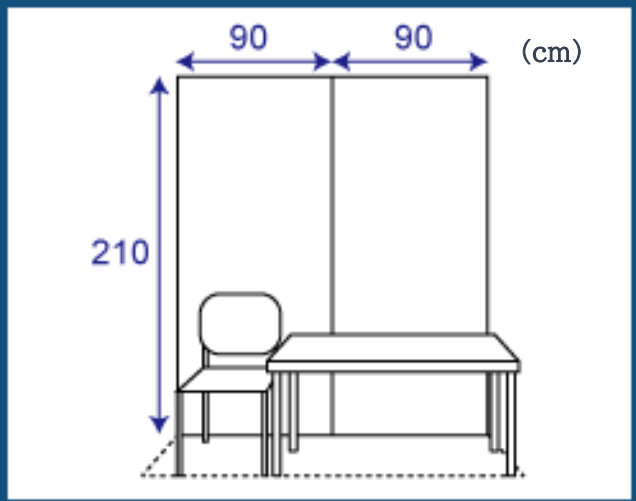
| | | |
|--------------------------------|--|--|
| Applicable to | University, Graduate School, etc. | |
| Exhibition fee | 84,700 yen (tax included) /booth | |
| Booth Size | W1800×D600×H2100 (mm) | |
| Included in the exhibition fee | (1) One set of back panel (W1800 x H2100) (2) One company name plate x 1 (W420 x H300) (3) Table x 1 (W1200 x D600 x H700) (4) Cloth (white) x 1 (5) Chair x 1 | |
| Exhibitor Pass to be provided | a. Exhibitor Pass A x 1 *Entitles the exhibitor to enter all area, including the lecture rooms, throughout the entire Meeting period, in the same way as general attendees. b. Exhibitor Pass B x 2 *Entry to the exhibition area only c. Online Meeting Pass x 3 | |
| Booth Details |  | |
| | Name Board size | W 420 X H300 |
| | Back Panels | Cross-lining *Please use thumbtacks for displaying posters, etc. or hooks & chains for displaying panels, etc. Hooks and chains are not provided on site, so that please bring your own ones. |
| | Floor surface | Carpeted |
| | Table | W1200 x D600 x H700 x 1 |
| Others | <ul style="list-style-type: none"> ➤ Please select items other than the above basic specifications from the list of optional items. ➤ Power supply is not available. It is an optional item. ➤ Basic specifications will be installed by the JpGU Office and delivered to exhibitors. ➤ There is no waiting room for exhibitors. | |

【Science Society Desk】

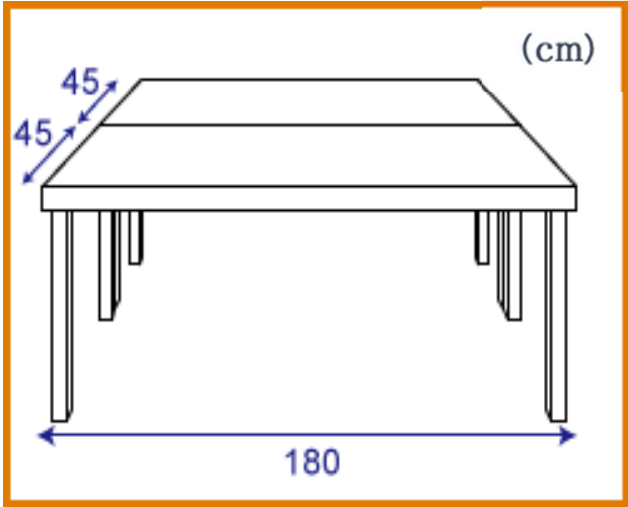
| | | |
|--------------------------------|--|--|
| Applicable to | Academic Societies, Associations, etc. | |
| Exhibition fee | Society members: 36,300 yen (tax included) / booth Non-society members: 48,400 yen (tax included) / booth | |
| Booth Size | W1800 x D900 (mm) | |
| Included in the exhibition fee | (1) Table x 2 (W1800 × D450 × H700) (2) Cloth (white) x 2 (3) Chair x 2 | |
| Exhibitor Pass to be provided | a. Exhibitor Pass B x 2 *Entry to the exhibition area only a. Online Meeting Pass x 2 | |
| Booth Details |  | |
| | Name Board size | W420*H300 (mm) |
| | Floor surface | Carpeted |
| | Table | W1800 x D450 x H700 x 2 Cloth (white) x 2 |
| Others | <ul style="list-style-type: none"> ➤ Please select items other than the above basic specifications from the list of optional items. ➤ Power supply is one of optional items. ➤ The basic specifications will be installed by the JpGU Office prior to exhibitor's set-up. ➤ There is no waiting room for exhibitors. | |

6. Optional Items

【Publishers Desk, University Panel, Science Society Desk】

List of Optional Items

A 10% administration fee will be charged separately.

*Please apply through the Registration system for exhibitors by April 25.

Power Supply



300W (single-phase 100V 50 Hz, with two outlet socket X 1)
5,500 Yen (tax included)

- The outlet shape provided by the venue is the normal A type. If you need a shape other than this, please bring your own conversion connector.
- If you need 3-phase or 200V power, please contact Makuhari Messe.

Arm Light



*Fixed between booth panels, etc.
3,300 yen (tax included)
 *Power consumption: 20W

Catalog Stand (Tabletop)

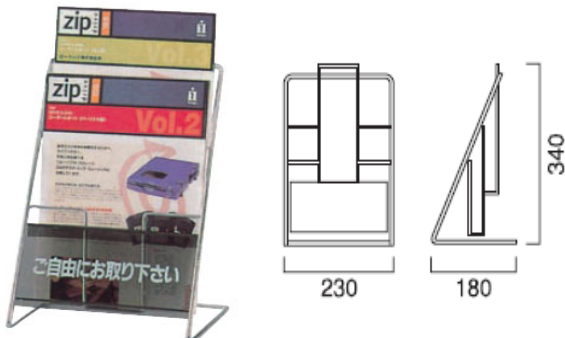

W230 x H340 x D180
3,300 yen (tax included)
 *Supports A4 vertical

Catalog stands (floor-standing)

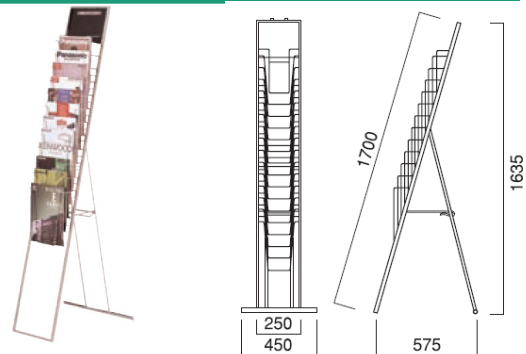

W250 x H1635 x D575
6,600 yen (tax included)
 *Supports A4 vertical

Panel Stand 1

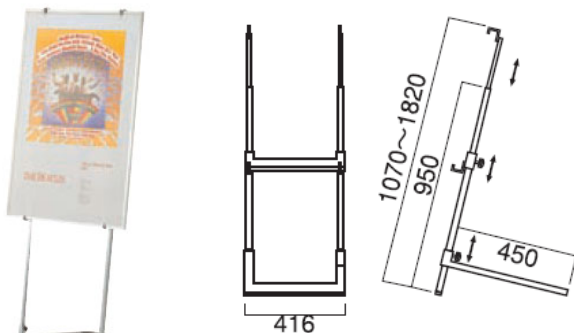

W416 x H1070-1820 x D450
8,800 yen (tax included)
 *Panels are not included.

Panel Stand 2

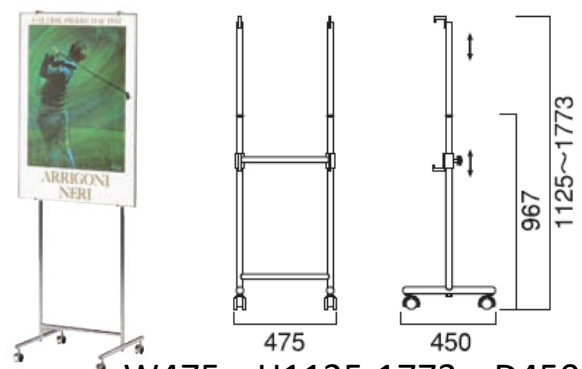

W475 x H1125-1773 x D450
7,700 yen (tax included)
 *Panel is not included.

Poster Board

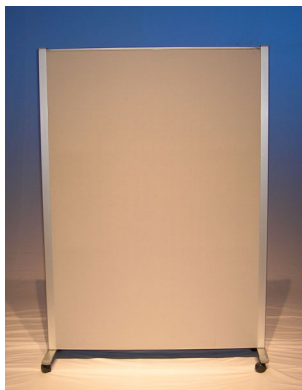

W1300×H1850,

drawing studs
can be used

*not available to
the university
panel are.

¥5,500
(tax included)

Internet Line

High-Speed Fiber Optic Line
NTT FLET'S Hikari Next Gigabit Line
Plan

*Supplied as a set of line, provider
(PPPoE), and router.

*Exhibitors are required to bring
your own HUB, LAN cables, etc.

*Up to approximately 1 Gbps (best-
effort type service)

110,000 yen (tax included)

Carry-in/out Vehicle Pass

If Exhibitor wish to carry in/out
vehicles, please apply in advance
for the desired number of Carry-
in/out Vehicle Pass through the
Registration system for exhibitors.
The Vehicle Pass will be sent in
PDF format.

Free of charge

7. Venue Service

1. Internet Service

(1) Free Wi-Fi at the International Conference Hall

- Free Wi-Fi is available at the International Conference Center.
SSID: MESSE-WiFi / PWD: m-messe36
- Connection may be difficult depending on capacity, number of users, individual PC settings and functions, and location.
- Please note that users are responsible for their own anti-virus and security settings.
- Individual support for connection will not be provided.
- Since the entire hall is shared with Meeting attendees, it may be difficult to connect due to the number of users, individual device settings and functions, and other factors. Internet service may be interrupted without prior notice for certain reasons.
- If you need a dedicated connection for your exhibit booth, it is offered as an optional item.

(2) Free Wi-Fi at Makuhari Messe Facilities (2F Central Mall)

- How to connect
 - ① Activate the Wi-Fi function on your Wi-Fi-enabled device.
 - ② Select "Messe_Free_Wi-Fi" from the list of available SSIDs and connect.
 - ③ When you stand up the browser, the top screen for users will appear.
 - ④ Please confirm the Terms of Use and register your e-mail address.
- Supported Languages Japanese, English, Chinese, Korean
- Time limit : Use Messe_Free_Wi-Fi for 30 minutes per use.
(There is no limit to the number of times you can use it per day.)
- After exceeding the limit, the top screen for users will be displayed again.

2. Personalized workboxes

- Workboxes with excellent soundproofing and sound insulation are located in the central mall on the 2nd floor.
- Please refer to the website of each URL for more details
Central Entrance: <https://waim-group.co.jp/chatbox/>
In front of Exhibition Hall 8: <https://telecube.jp/location/makuharimesse/>

3. Mobile battery stand

- Rental mobile batteries are available.
- For detailed information, please refer to the website. <https://chargespot.jp/>

4. Restaurant and Convenience store

① WORLD KITCHENS!

- Cafeteria where you can enjoy world cuisines *Non-smoking
- Location 2F Central Mall,
in front of Exhibition Hall 6

*Please confirm the date and time of operation at the site on the day of the event.

② New Yamazaki Dairy Store

- Location 2F Central Entrance
- * Please confirm the date and time of operation at the site on the day of the event.

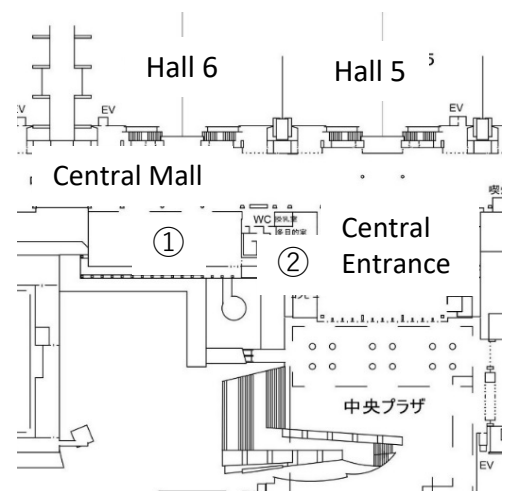

*For venue services, please refer to the Makuhari Messe Web site.

<https://www.m-messe.co.jp/facility/>

8. Carry-in

1. Carry-in time and date

- On the day before the exhibition and the first day of the exhibition, you can bring in and set up your booth during the following hours.
- Day before the exhibition: Saturday, May 24, 3:00 p.m.- 6:00 p.m.
*carry-in only, no set-up
- First day of the exhibition: Sunday, May 25, 8:30 a.m. - 10:00 a.m.

Please let JpGU Office know how to bring in your booth by May 15 (Thu.) through the registration system for exhibitors.

2. Exhibitor Pass

- Please be sure to wear your Exhibitor Pass while you are in the venue.
- Please bring your "e-Ticket" to the 1st floor of the International Conference Hall of Makuhari Messe to have your Exhibitor Pass issued.
*How to issue an Exhibitor Pass
Exhibitors can issue and print "e-Tickets" on the Registration system for exhibitors. Please bring the printed copy to entrance of the 1st floor of the International Conference Hall to print an Exhibitor Pass.
- You cannot make your presentation using this Exhibitor Pass.

Registration system for exhibitors
Japan Geoscience Web site ⇒ Menu by visitor "Exhibitors"
⇒ For those who have already applied "Log in".
<https://www.jpгу-member.org/exhibition-booth2025/mypage/>

3. Carry-in with a vehicle

Please bring and show your Vehicle Pass applied in advance at the East Gate 2.
Please follow the instruction of the venue staff.

4. Using a courier service

- Please send your items to arrive on [the afternoon of Saturday, May 24th] or [the morning of Sunday, May 25th.]
- Please fill out the invoice according to the sample below. Also, please write the package number/total number on the invoice and on each package.
- Packages will be delivered to each booth by the courier company. If you are going to receive the packages by yourselves, please checkmark the box in the Registration system for exhibitors.
- Makuhari Messe Inc., recommends Yamato Transport as the courier service provider.

【Sample invoice】

[Address]

2-1 Nakase, Mihama-ku, Chiba City
Chiba, 261-8550 Japan
Makuhari Messe
International Conference Hall,
JpGU Meeting 2025 Publishers Desk
No. 00 (Your booth number)
Exhibitor's name (as registered)
TEL: 043-296-0694 ←

[Product Name]

Name: Publishers Desk Booth No. _____.
Organization: Name of exhibitor/organization
(please fill in correctly)
No. of items/total number of items
*Example: No. 1 / Total 10 pieces

*This is the phone number of the venue.
If you wish to be present, please provide
the cell phone number of the person in charge.

*Caution

- Please keep a copy of the invoice, etc., and take care of any undelivered or lost items by yourself.
- Please do not block aisles or other spaces.
- If heavy items are to be brought into the booth, please cure the floor when necessary.

5. Sending items from overseas

- The following international shipping company is recommended. Customs clearance procedures may take some time, so please make your request as soon as possible.
- Contact:
Rock-it Cargo Japan Inc.
1-6 Nakase, Mihama-ku, Chiba-City, Chiba 261-0023
mBAY POINT Makuhari 16F
Tel: +81-43-298-4741
Mobile phone: 090-9157-2582(+81-90-9157-2582)
E-mail: taka.matsute@rockitcargo.com (Attn: Takanori Matsute)
*Please use "JpGU2025" as the subject of the e-mail.
- If you request another shipping company, please refer to the above [sample invoice] and be sure to provide details including the date and time of delivery so that you can pick up the package directly on the designated delivery date and time by yourself.
- JpGU Office and Makuhari Messe, inc. will not be able to pick up or keep your items even if it arrives before the carry-in date. The JpGU Office will not be able to handle customs clearance procedures on your behalf.

9. Dismantling

1. Date and time of dismantling

Friday, May 30, 4:00 p.m. - 6:00 p.m.

2. Using the Makuhari Messe-designated courier service

- You can use the courier service designated by Makuhari Messe (Yamato Transport, collect on delivery only).
- Yamato Transport will pickup the packages around 6:00 p.m. on Friday, May 30.
- Please fill out the necessary information on the invoice and bring the package to the pickup locations (see figure below) on May 30 (Fri.).
- The invoice will be available at Yamato Transport Desk.

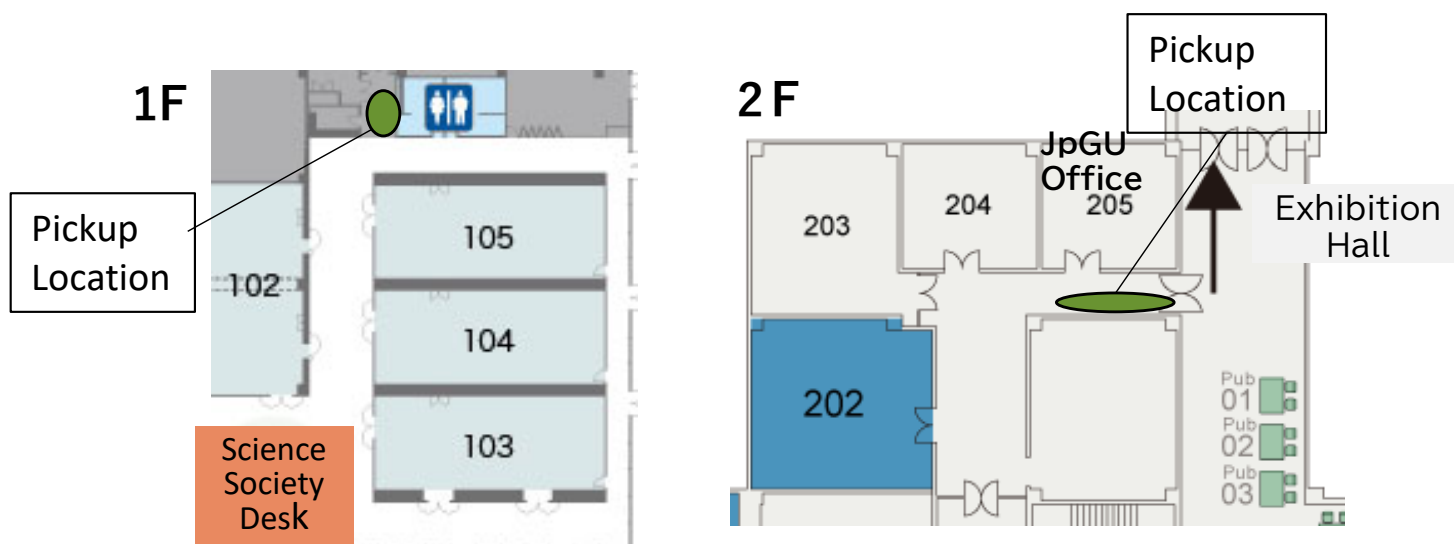

3. Making your own arrangements

- If you use other courier companies, etc., please contact them by yourself. "Carry-in/out Vehicle Pass" will be required.

4. Other requests

- Although the organizers will make every effort to ensure security from carry-in to carry-out, the JpGU Office cannot be held responsible for theft or loss of exhibits, etc. Please be careful with your items.
- Please be careful not to cause danger in the exhibition hall, as people will be moving around during poster presentations, etc.
- Please be careful not to bring out the venue items or equipment including white cloth.

10. Carrying in/out Route

1. Car Carry-in/out route

- Please enter the East Gate2 exit at the North Gate.
- At the East Gate 2, please show the "Carry-in/out Vehicle Pass" issued by the venue (Makuhari Messe) to the security guard.
- "Carry-in/out Vehicle Pass" must be applied for in advance via the Registration system for exhibitors.
- Please park your vehicle in accordance with the instructions on your vehicle pass and venue staff.
- No vehicles are allowed to enter the hall. Please carry your item with a cart, etc. from the loading exit.

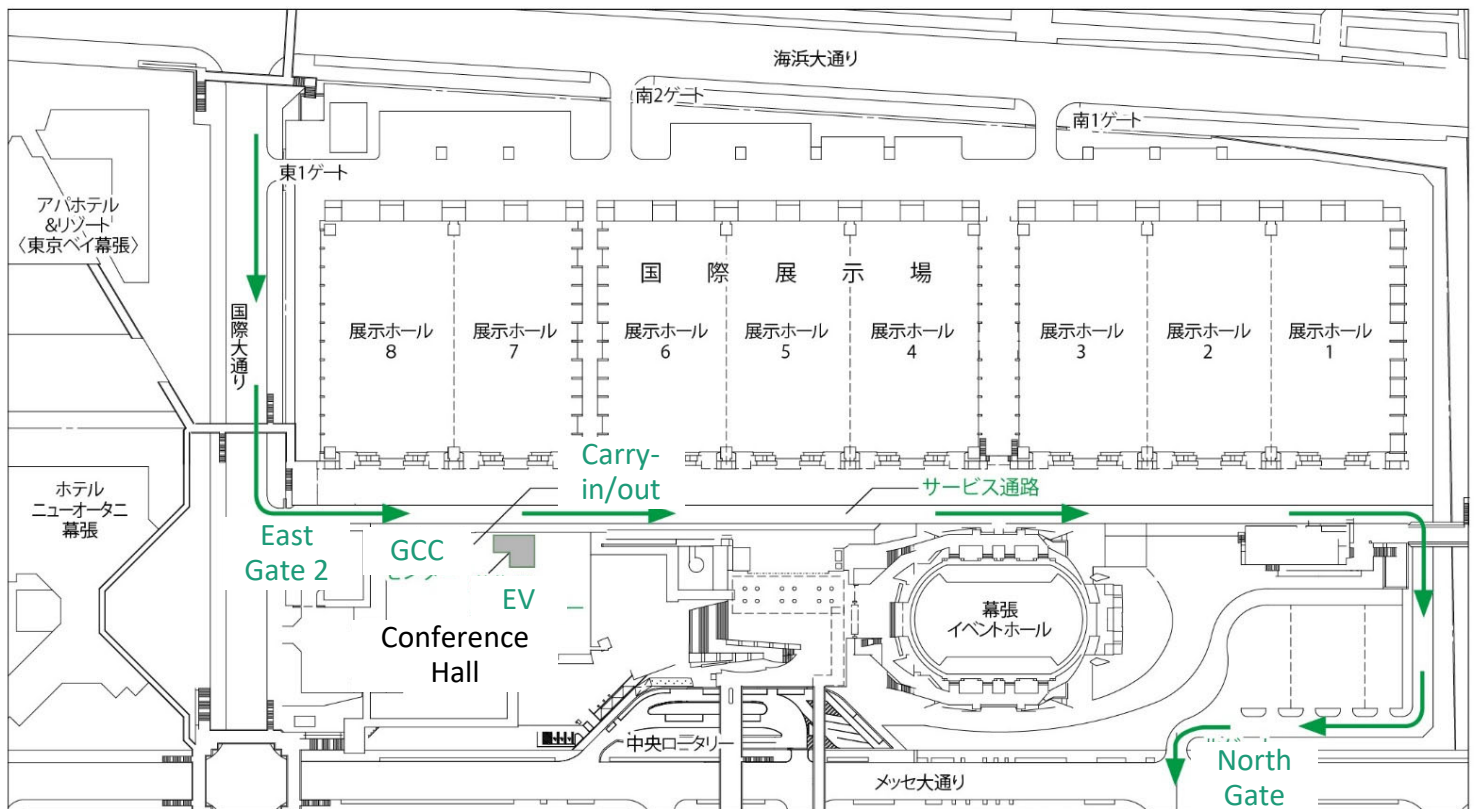

2. Carrying-in/out route in the International Conference Hall

- Please use "the service entrance" near the General Control Center for carry-in/out on the 1st floor of the International Conference Hall.
- Please use "Elevators for loading" for carry-in/out on the 2nd floor.
 - Elevator for loading (large)
: W2.35m x D5.40m x H2.40m, Loading capacity limit 3,200kg
 - Elevator for loading (small)
: W2.20m x D2.80m x H2.10m, Loading capacity limit 2,000kg
- When transporting heavy or large materials, be sure to protect the doors and carpets on each floor.

11. Precautions

Please confirm the following rules and regulations.

1. General

- The Japan Geoscience Union (JpGU) will be responsible for the overall management of the venue as the administrator, but in principle, exhibitors are responsible for managing their own belongings in your booths and exhibits. JpGU will not be held responsible for any damage, loss, or theft of exhibits.
- No storage space is provided for exhibits. If you have valuables, do not leave your booth unattended. In addition, please take necessary insurance procedures on your own.
- JpGU reserves the right to change or cancel the exhibition period due to natural disasters or other force majeure. JpGU will not compensate for any loss or damage incurred by exhibitors or related parties as a result of such changes or cancellations.
- Exhibitors are prohibited from transferring or exchanging all or part of your booths to others without JpGU's permission.
- Please confirm the designated carry-in/out times and exhibition periods. If you have any unavoidable requests, please contact the JpGU as soon as possible.
- Exhibitors whose exhibits do not meet to the event may be denied entry.

2. Setup and installation

- Direct construction (taping, nailing, scraping, attaching, etc.) on the floor, walls, etc. of the venue is strictly prohibited. Please do not damage or deface the venue, including during carry in/out.
- Ceiling structures are prohibited. The height of exhibits and decorations must be 2.1m or less. If the height is unavoidably exceeded, please consult with the secretariat in advance.
- Please contact Makuhari Messe, Inc. if there are heavy items to be exhibited. The maximum load capacity of the floor is 360kg/m² (contact Makuhari Messe, Inc. for pit areas).
- Plywood, rugs, curtains, etc. used for booth decorations must be fire-retardant. Flameproof items must be labeled with flameproof markings as stipulated in the Fire Prevention Law Enforcement Regulations.
- According to the Chiba City Fire Prevention Ordinance, smoking, the use of naked flames (including appliances with exposed heating elements), and the bringing in and use of hazardous materials are prohibited in the museum (hazardous materials: propane gas, high-pressure gas, gasoline, kerosene, petroleum, gunpowder, etc.). However, if it is unavoidable to bring in such items for demonstration of exhibits, etc., it may be allowed under certain conditions with permission from the Chiba City Fire Department.

- Exhibitors are responsible for taking all waste materials, packing materials, garbage, etc. generated during carry-in, carry-out, and exhibit. Exhibitors who leave residual materials in the venue after the event will be charged a disposal fee.
- No storage space is provided for empty boxes, packing materials, or replenishment products. Please take them home with you or use the area under the desks in your booth.
- If any problems or hazards are found in the construction or decoration of the booth, JpGU and Makuhari Messe, Inc. may request changes to be made.

3. During the exhibition period

- Construction work or exhibits that generate noise, vibration, odor, smoke, etc. that interfere with the management and operation of the venue are prohibited.
- Please adjust the volume of audio/visual equipment in your booth and the volume generated by display equipment so as not to disturb other exhibitors or attendees. If there are complaints on the day of the event, the use of the equipment may be discontinued. *Excessive volume may interfere not only with other exhibitors, but also with simultaneous broadcasts in the event of an emergency or with the operation of the conference.
- It is prohibited to conduct PR activities, etc. in areas beyond the exhibitor's booth, or to place exhibitor's equipment or items in areas other than the exhibitor's booth.
- When it is recognized that there is some obstacle or danger to the operation of the meeting, JpGU and Makuhari Messe, Inc. may ask the exhibitor to make changes to the booth.