

A banner for the Japan Geoscience Union Meeting 2023. The background is a collage of geoscience-related images: a green aurora borealis, a satellite view of Earth, a green forest, and coral reefs. The text is overlaid on a white rectangular background.

# Japan Geoscience Union Meeting 2023

MAY 21 - 26, 2023

On-site : MAKUHARI MESSE, Chiba, Japan

Online : all over the WORLD

For a Borderless World of Geoscience 

## **Exhibition Guidance**

- Publishers Desk-
- University Panel-
- Science Society Desk-



Japan Geoscience Union

# 1. Outline of JpGU Meeting 2023

## Outline

Name of the meeting	Japan Geoscience Union Meeting 2023
Dates	MAY 21 - 26, 2023
Meeting format	Hybrid (In-person and online )
On-site venue	MAKUHARI MESSE, Chiba
Host	Japan Geoscience Union

## Society Members :

Japanese Society for Biological Sciences in Space, Japan Society of Engineering Geology, The Japanese Society of Hot Spring Sciences, The Oceanographic Society of Japan, The Volcanological Society of Japan, Society of Science on Form Japan, Japanese Society for Active Fault Studies, Meteorological Society of Japan, Japan Association of Mineralogical Sciences, Japan Cartographers Association, The Paleontological Society of Japan, The Japanese Association for Arid Land Studies, The Society of Resource Geology, The Seismological Society of Japan, Japan Society of Geoinformatics, Japanese Association of Hydrological Sciences, Japan Society of Hydrology & Water Resources, Society of Eco-Engineering SEE, The Society for the Study of the Origin and Evolution of Life Japan, The Japanese Association for Petroleum Technology, The Japanese Society of Snow and Ice, The Geodetic Society of Japan, The Japan Society of Atmospheric Chemistry, The Sedimentological Society of Japan, Japan Association for Quaternary Research, Japan Society of Earth Science Education, The Association for the Geological Collaboration in Japan, Japanese Association of Groundwater Hydrology, The Geochemical Society of Japan, Society of Geomagnetism and Earth, Planetary and Space Sciences, Japanese Geomorphological Union, The Geological Society of Japan, The Geothermal Research Society of Japan, The Japanese Society for Geographical Sciences, The Association of Japanese Geographers, The Geographic Education Society of Japan, Geographic Information System Association of Japan, Tokyo Geographical Society, The Tohoku Geographical Association, Japanese Society of Soil Physics, The Clay Science Society of Japan, The Society of Agricultural Meteorology of Japan, The Society of Exploration Geophysicists of Japan, The Japanese Society of Physical Hydrology, The Remote Sensing of Society Japan, The Japanese Society for Planetary Sciences, PALEO10: Paleosciences Society, Society of Atmospheric Electricity of Japan, Japan Society for Natural Disaster Science, The Japanese Association of Organic Geochemists

## Supporting Members :

Regional city Convention attraction Promotion Council, FORTE Science Communication, ASO UNESCO GLOBAL GEOPARK, Crimson Interactive Japan, WorldCreations Inc, Japan Geopark Network, American Journal Experts, CACTUS COMMUNICATIONS K.K., Chiba Convention Bureau and International Center, Reseablic Inc., TECH OCEAN

## Co-sponsor :

Japan Society of Civil Engineers, Japan Association for Earthquake Engineering, The Japanese Geotechnical Society, Japan Society of Erosion Control Engineering, The Japan Society of High Pressure Science and Technology

## Sponsorship :

" Science Council of Japan / Ministry of Education / Culture, Sports / Science and Technology-Japan / Meteorological Research Institute / Kakioka Magnetic Observatory / Japan Meteorological Agency / Hokkaido Research Organization / Japan Oil, Gas and Metals National Corporation / National Museum of Nature and Science / Japan Aerospace Exploration Agency / Japan agency for Marine-Earth Science and Technology / National Institute for Environmental Studies Japan / National Institute of Advanced Industrial Science and Technology / National Institute of Information and Communications Technology / Forestry and Forest Products Research Institute / Institute for Rural Engineering, NARO / National Institute for Materials Science / National Research Institute for Earth Science and Disaster Resilience / RIKEN / High Energy Accelerator Research Organization / National Institute of Polar Research / Japan Geotechnical Consultants Association / The Institute of Electronics, Information and Communication Engineers / " Japan Analytical Instruments / Manufacturers' Association / Central Research Institute of Electric Power Industry / Japan Space Forum / Fukada Geological Institute / Japan Association of Surveyors / The Japan Landslide Society

# 2-1. Outline of Exhibition

## 1. Publishers Desk, University Panel, Science Society Desk

Dates : Sunday, MAY 21 – Friday, May 26, 2023 \*6 days

Venue : International Conference Center 1F /2F Lobby

Exhibition Fee (tax included)

Publishers Desk: 55,000 JPY/booth

University Panel: 77,000 JPY / booth

Science Society Desk: Society member 33,000 JPY / booth  
non-Society member 44,000 JPY / booth

If 2023 Meeting shifts to an online meeting, only "Online Exhibition" will be available. In that case, all applications other than "Online Exhibition" will be cancelled. Thank you in advance for your understanding.

## 2. Schedule

Session	Time	May 20	May 21	May 22-25	May 26
		The previous day	The first Day	2nd-5th day	The final day
8:30 Open	8:00AM				
AM1 9:00~10:30	9:00		Carrying-in Installation 8:30~10:00		
AM2 10:45~0:15	10:00		Show Hours 10:00~5:00		Show Hours 10:00~4:00
Lunch 0:15~1:45	11:00				
PM1 1:45~3:15	0:00PM				
PM2 3:30~5:00	1:00				
Exhibition Hall 8 PM3 5:15~6:45 (On-site Poster Core Time)	2:00				
	3:00	Carrying-in 3:00~6:00  *No set up.			Dismantling 4:00~5:30
	4:00				
	5:00				
	6:00				
	7:00				
	8:00				

## 2-2. Outline of Exhibition

### 3. Contact

Details of this booklet

(About the venue, option items, carrying-in and out)

Makuhari Messe, Inc. In charge of JpGU Meeting 2023 venue  
Takayama (Ms.) , Shimizu (Mr.)

2-1, Nakase, Mihama-ku, Chiba-city, 261-8550 Japan

TEL : +81-43-296-0694 E-mail : [jpgu@m-messe.co.jp](mailto:jpgu@m-messe.co.jp)

(About meeting, exhibition, and general information)

Japan Geoscience Union Office

In charge of the exhibitions, Sugimura (Mr.)

2-4-16 Yayoi, Bunkyo-ku, Tokyo, 113-0032, Japan

Email: [exhibition@jpgu.org](mailto:exhibition@jpgu.org)

### 4. Venue Map

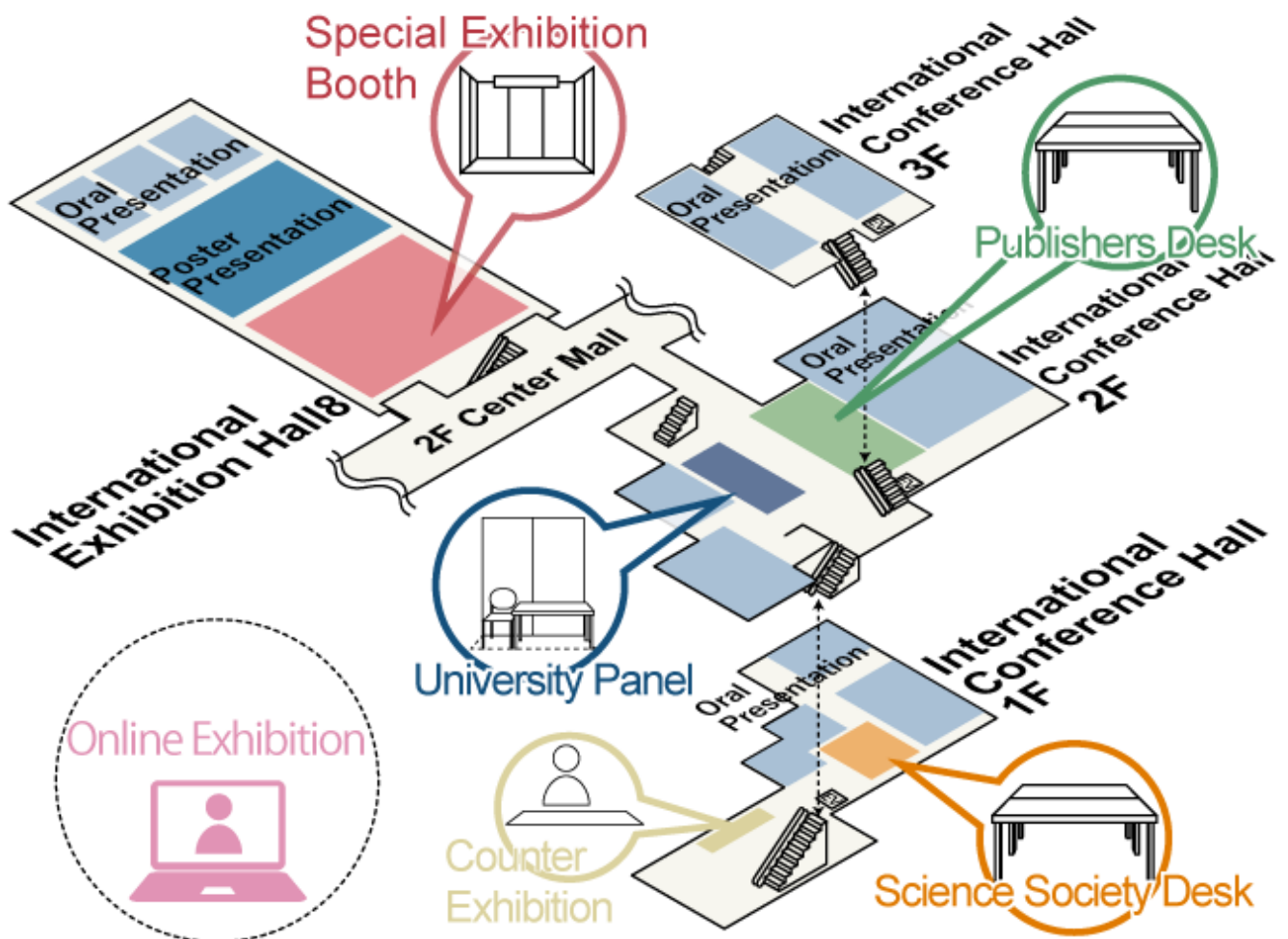

# 3-1. Floor Plan : 1F Lobby – Science Society Desk

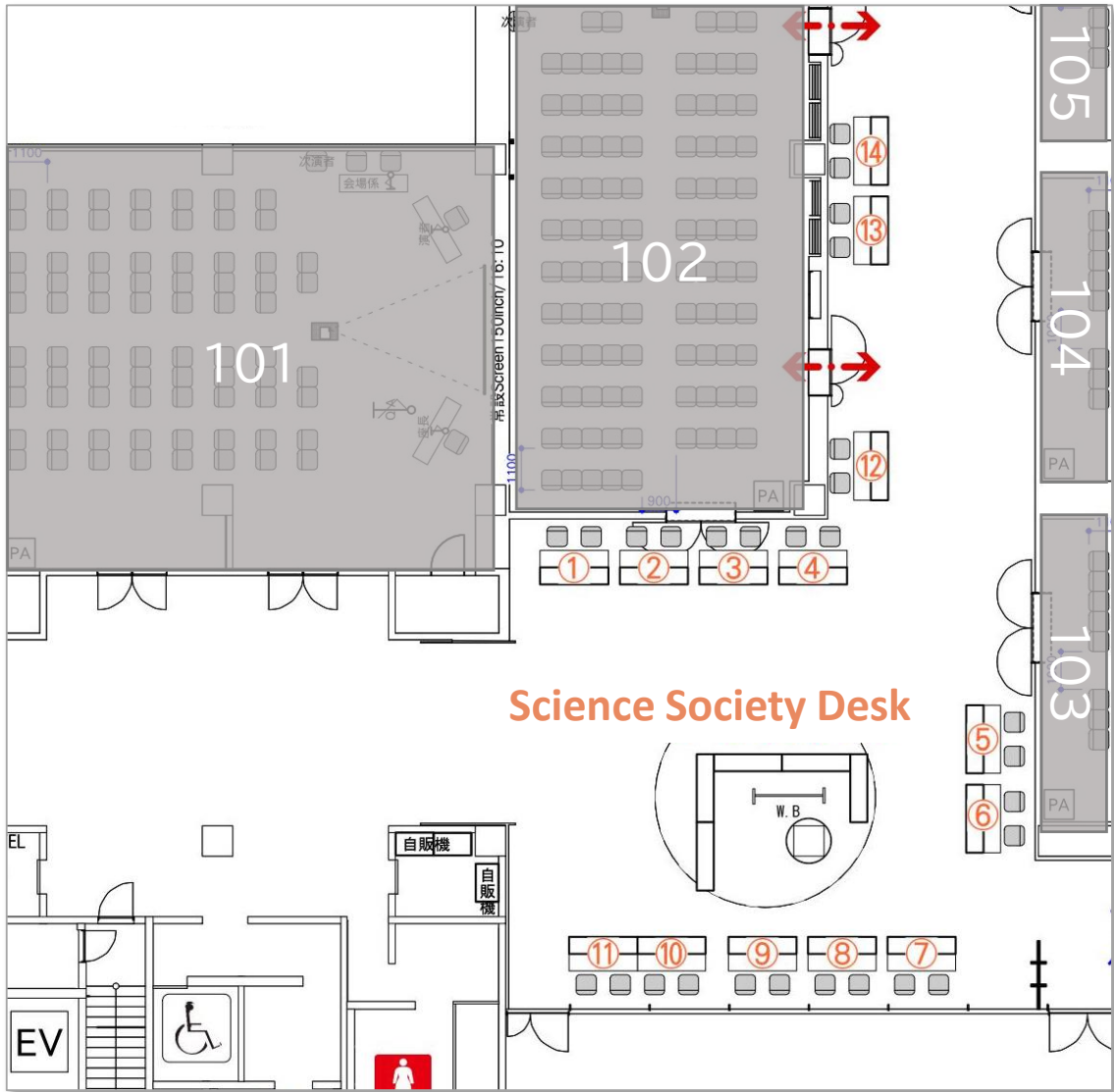

Booth No.	Science Society Desk/ Exhibitor Names
Soc01	The Oceanographic Society of Japan
Soc02	
Soc03	Palaeontological Society of Japan
Soc04	The Society of Exploration Geophysicists of Japan
Soc05	Geochemical Society of Japan
Soc06	Society of Geomagnetism and Earth, Planetary and Space Sciences
Soc07	International Union of Geological Sciences (IUGS) -- Deep-time Digital Earth (DDE)

Booth No.	Science Society Desk/ Exhibitor Names
Soc08	The Volcanological Society of Japan(VSJ)
Soc09	The Geological Society of Japan
Soc10	
Soc11	Japan Association of Activation Analysis, JA3
Soc12	The Geodetic Society of Japan
Soc13	
Soc14	

\* These lists are as of March 30 2023.

# 3-2. Floor Plan : 2F Lobby -

# University Panel/ Publisher Desk

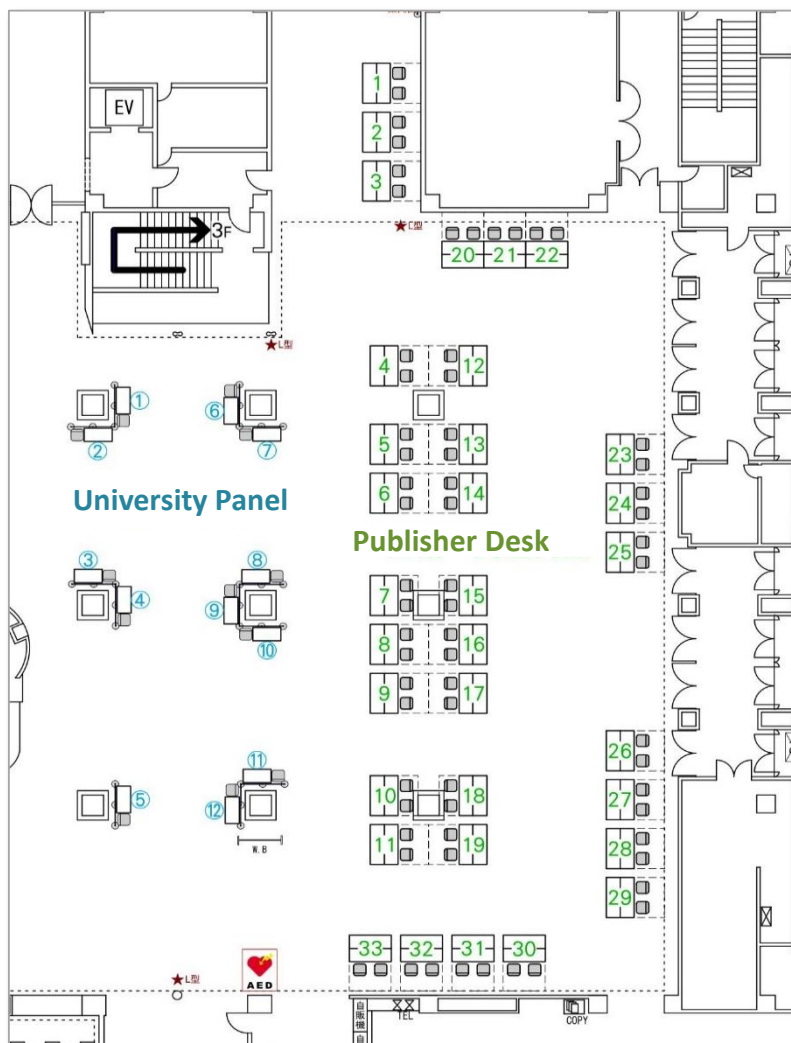

Booth No.	Publishers Desk/ Exhibitor Names
Pub01	KYORITSU SHUPPAN CO., LTD.
Pub02	
Pub03	
Pub04	RC GEAR
Pub05	
Pub06	Geogashi-Ryokodan
Pub07	Kokon Shoin
Pub08	Nihon-Mic Co.,Ltd
Pub09	Asakura Publishing Co.,Ltd.
Pub10	University of Tokyo Press
Pub11	Sairisha
Pub12	
Pub13	
Pub14	
Pub15	
Pub16	
Pub17	
Pub18	
Pub19	
Pub20	
Pub21	NICHIKA INCORPORATED
Pub22	
Pub23	
Pub24	
Pub25	Minna de Honkoku
Pub26	Springer Nature
Pub27	
Pub28	
Pub29	
Pub30	Neutrino Tokyo Inc.
Pub31	
Pub32	
Pub33	

Booth No.	University Panel / Exhibitor Names
Univ01	Departments of Geophysics and Earth Science, Tohoku University
Univ02	The International Joint Graduate Program in Earth and Environmental Sciences, Tohoku University
Univ03	Tohoku University WISE Program for Sustainability in the Dynamic Earth
Univ04	Department of Earth and Environmental Sciences, Graduate School of Environmental Studies, Nagoya University
Univ05	Department of Geography, Tokyo Metropolitan University
Univ06	University of Aizu
Univ07	Center for Data Assimilation Research and Applications, Joint Support Center for Data Science Research
Univ08	Graduate School of Geo-Environmental Science, Rissho University
Univ09	Atmosphere and Ocean Research Institute, the University of Tokyo
Univ10	Earthquake Research Institute, The University of Tokyo
Univ11	Department of Earth and Planetary Sciences, Hokkaido University
Univ12	Institute of Low Temperature Science, Hokkaido University

\* These lists are as of March 30 2023.

## 4. Venue Service

### **1. Free Wi-Fi at International Conference Hall**

- Free Wi-Fi service is available at lobby at the International Conference Hall.  
( SSID: MESSE-WiFi / PASS: nakase2-1 )
- We don't provide configuring service. Please be responsible for security of your own PC or other devices.
- Please note that Wi-Fi service may be suspended without notice.
- We cannot guarantee the safety of the connection, connectivity and the internet speed.
- Connectivity and accessibility will depend on the circumstance of the venue.

## 5-1. Booth Plan : Publisher Desk

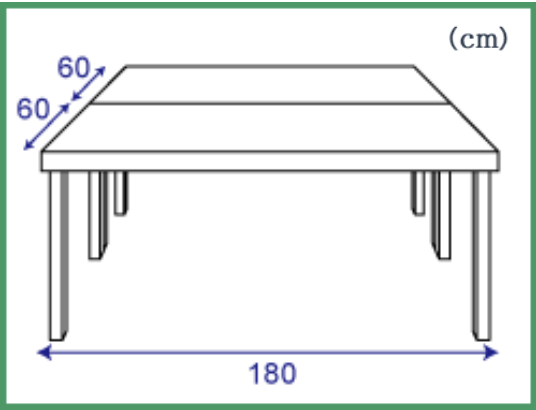
Exhibition Fee	55,000 JPY / booth	
Booth Size	Exhibition Space : 1800*1200 (mm)	
Booth fee includes the followings	Table (W1800*D600*H700) 2 Tablecloths (white) 2 Chairs	
Passes	2 Exhibitor Pass B Permission to enter only exhibition area 2 online Meeting Pass *No additional Pass are provided without charge.	
Details	 <p>(cm)</p>	
	Name Board size	W420 * H300
	Table	W1800 * D600 * H700 : 2 2 Table cloths (white)
Options	Electrical source is not supplied.	

- Please refer to 6-1., 6-2. for charged optional items.
- Basic installation will be set up by the JpGU Office.

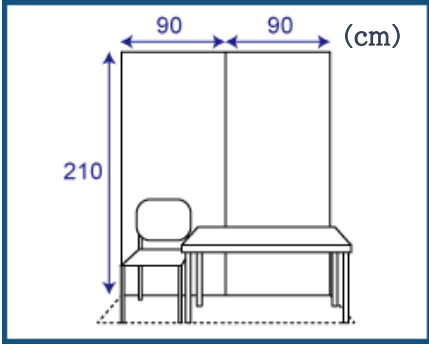

## 5-2. Booth Plan :University Panel

Exhibition Fee	77,000 JPY /booth (tax included)	
Booth Size	W1800×D600×H2100 (mm)	
Booth fee includes the followings	1 set of side panels, (W1800*H2100) 1 Nameplate (W420 * H300) 1 Table (W1800* D600 * H700) 1 tablecloth 1 Chair * There's no electric power supply.	
Passes	1 Exhibitor Pass A Permission to enter all rooms and exhibition area 2 Exhibitor Pass B 3 online Meeting Pass Permission to enter only exhibition area	
Details		
	Name Board size	W 420 * H300
	Back Panels	covered with cloth (Pins, hooks and chains are available. There are no hooks and chains at the venue. Please be sure to bring them by yourselves.)
	Floor	Carpeted
	Table	W1200* D600 * H700 : 1
Options	Electrical source is not supplied.	

- Please refer to 6-1., 6-2.for charged optional items.
- Basic installation will be set up by the JpGU Office.

## 5-3. Booth Plan :Science Society Desk

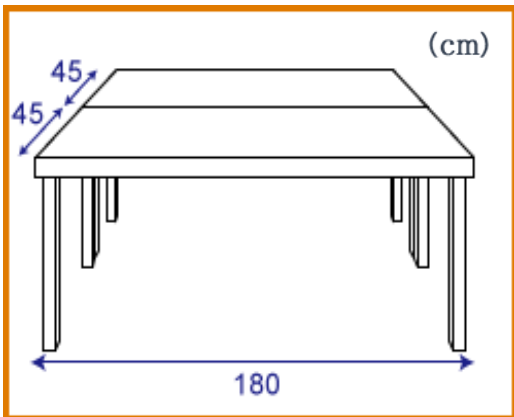
Exhibition Fee	Society member 33,000 JPY / booth (tax included) 44,000 JPY / booth (tax included)	
Booth Size	Exhibition space : W1800*D900 (mm)	
Booth fee includes the followings	1 Table (W1800*D450*H700) 2 Table cloths (white)*2 2 Chairs	
Passes	2 Exhibitor Pass B Permission to enter only exhibition area 2 Online Pass *No additional Pass are provided without charge.	
Details	 <p>The diagram shows a trapezoidal table with a top width of 180 cm, a height of 45 cm, and a depth of 45 cm. The dimensions are labeled in blue with arrows. The unit '(cm)' is indicated in the top right corner of the diagram.</p>	
	Name Board size	W420*H300 (mm)
	Table	W1800* D450*H700 : 2 Table cloth (white): 2
Options	Electrical source is not supplied.	

- Please refer to 6-1., 6-2. for charged optional items.
- Basic installation will be set up by the JpGU Office.

# 6-1. Optional items

( Publishers Desk, University Panel, Science Society Desk )

## Option Item List

\*10% consumption tax included

Please place your order through the exhibition application system.

### Arm light



3,850 JPY (tax included)  
Power supply and a panel etc. for clip are needed. Electricity 20W.

### Catalog stand (desk)

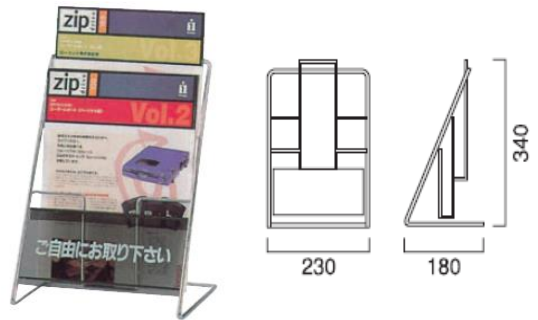

3,300 JPY (tax included)  
Size: W230 \* H180 \* D340 (A4)

### Catalog stand (floor)

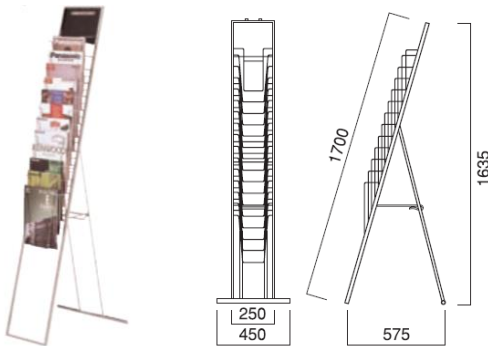

6,600 JPY (tax included)  
Size: W250 \* H 1635 \* D 577 (A4)

### Panel stand 1

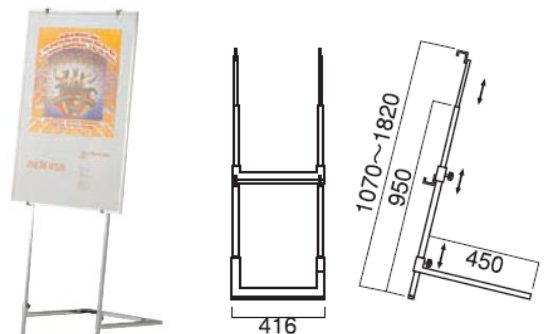

8,800 JPY (tax included)  
416\*(1070~1820)\*450  
\*Panels are not included.

### Panel stand 2

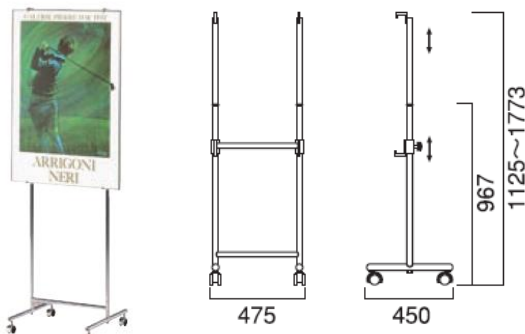

7,700 JPY (tax included)  
W475\*(H1125~1773)\*D450  
\*Panels are not included.

### Poster board

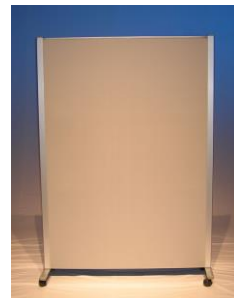

5,500 JPY (tax included)  
W 1300 \*H1850 You can use pins.  
※Not available at University Panel area.

## 6-2. Optional items (Special Exhibition Booth)

### Electrical Power Supply



5,500 JPY (tax included)  
300W  
(single-phase 100V 50Hz, a duplex receptacle: Type A)

Please bring your plug converters as you need. If you have any request such as three phase or 200V, Venue will estimate the price.

### Paid Wired Internet

Optical line  
110,000JPY/ line (tax included)

Public Wi-Fi is for short term use.  
Please send application for exclusive wired leased line for your booth.

### Vehicle Pass



地球惑星科学連合2023大会  
JpGU2023

国際会議場 搬入出車両証

有効期間:

5/20(土)15時~5/26(金)

出展者名:

担当者名:

携帯電話番号:

※ 搬入出終了後は、速やかにご退会をお願いします。長時間の駐車はご遠慮ください。

Please request in advance for carry-in and carry-out by vehicles.

\* For free

Inquiries about the venue, options, carrying-in and out  
Makuhari Messe, Inc. In charge of JpGU Meeting 2023 venue  
Takayama (Ms.) , Shimizu (Mr.) E-mail : [jpgu@m-messe.co.jp](mailto:jpgu@m-messe.co.jp)

# 7. Payment

## 1. Booth fee

- Japan Geoscience Union office will bill you for the fee.
- For this once only, the payment will be made after the end of JpGU 2023.
- **Please issue the invoice through the online system by yourselves.** JpGU office will not send you any invoice directly.
- Please feel free to contact us if you need any extra procedure, such as Public Expenses, specified form, etc.
- **Please log in from the online system below and proceed to payment.**  
<https://www.jpгу-member.org/exhibition-booth/login/>  
Please choose credit card payment or bank transfer.

The bank account

SUMITOMO MITSUI BANKING CORPORATION Koishikawa Branch

Savings account:3761271 Japan Geoscience Union

Swift Code: SMBCJPJT

\* Please bear the bank transfer fee.

## 2. Option Item Fee

(option item rental fee, additional power supply, additional internet line, logo on a name plate)

- Makuhari Messe, Inc. will bill you for the fees.
- The person in charge will contact you directly regarding payment methods.

## 3. Cancellation

- As a general rule, cancellations will not be accepted once the application has been accepted. is not accepted basically after applying. If this is unavoidable, please notify the JpGU office by e-mail.
- Please note that cancellation fees will be charged from one week after registration.  
By April 30th (Sun) :50% of the booth fee  
After 5pril 1st (Mon) :100% of the booth fee

If 2023 Meeting shifts to an online meeting, only "Online Exhibition" will be available. In that case, all applications other than "Online Exhibition" will be cancelled. Thank you in advance for your understanding.

# 8-1. Carrying-in

## 1. Carrying-in Date

On the day before and the first day of the JpGU2013, you may bring in and set up during the following time.

- A day before : May 20th (Sat) 3:00PM – 6:00PM
- The first day : May 21st (Sun) 8:30AM – 10:00AM

Please inform the office by May 10 (Wed) of how to carry-in your items.

JpGU Meeting 2023 website -> Information for Exhibitors -> For exhibitors [ >> Log in ]  
<https://www.jpгу-member.org/exhibition-booth/login/>

## 2. Exhibitor Pass

- Please wear your exhibitor pass all the time in the venue.
- Please issue your pass through the online system in the venue.

\*How to issue

Please log-in to the online system and follow the guidance to print out your “**e-ticket**”, then bring it to the reception desk at the 1st floor of the International Conference Hall on site.

Please order through the online system

JpGU Meeting 2023 website -> Information for Exhibitors -> For exhibitors [ >> Log in ]  
<https://www.jpгу-member.org/exhibition-booth/login/>

- In case you make presentation, please register as a participant not only as an exhibitor.

## 3. Delivery by vehicle

- It is available on May 20th (Sat) 3:00PM – 6:00PM or May 21st (Sun) 8:30AM – 10:00AM.

### \* Vehicle Pass

- All the vehicles must show the [Vehicle Pass] to the security guard.
- Please confirm the delivery route and parking lot by the later page or the pass.
- No vehicles are allowed to drive in to the Exhibition Hall. Please use a hand cart.

## 8-2. Carrying-in

### 4. By Courier Companies (Domestic)

- The arrival date must be on May 20th PM or May 21st AM.
- Please make sure to write the invoice as the following sample, and make sure to write the number / the total number on all the packages.
- Packages will be delivered to your booth in the periods. If you need to receive your packages directly, please write your contact phone number on the “shipping remarks” of the invoice.
- Makuhari Messe recommends’ courier company is Yamato Transport.

#### [Sample of the invoice]

<p>[ Address ] 2-1, Nakase, Mihama-ku, Chiba-city, 261-8550 Japan Makuhari Messe, International Exhibition Hall 8 JpGU Meeting 2019 Special Exhibition Booth Booth No. A-XX(Your booth number) ← Exhibitor’s name (as registered) TEL:043-296-0694</p>	<p>[ Item ] Items: Special Exhibition Booth No. A- XX Exhibitor’s name (as registered) Package No. XX / Total XX *example, No.1 / 10</p>
	<p>Please write your mobile phone number if you need to receive your package directly at the venue.</p>

#### \* Note

- **Please bring a copy of the invoice and handle any undelivered or lost items by yourselves.**
- Please set up your booth in your own booth and do not block aisles or other spaces.
- If heavy items are to be brought into the exhibition hall, please install them after curing the floor and walls as necessary.

### 5. By International Courier Companies (Overseas)

- JpGU office recommends an international courier company below. Please contact the person in charge as soon as possible as it may takes long time for the customs clearance.

Name: Rock-It Global Inc.

Person in charge: Takanori Matsute (Mr.)

Address: mBAY POINT Makuhari 16F 1-6 Nakase, Mihama-Ku, Chiba-Shi,  
Chiba 261-0023, Japan

Tel: 81-43-298-4741 Fax: 81-43-298-4740

Mobile: 81-90-9157-2582

E-mail: taka.matsute@rockit.global

\* The title of the E-mail title should be “JpGU2023”.

- If you use another courier company, please make sure your packages will arrive during the above carrying-in period with referring to the delivery slip sample , and receive them directly on site from the company.
- JpGU office and the venue CANNOT pick up or hold any packages even if they arrive before the carrying\*in date. Please also note that the office and the venue will not handle customs clearance procedures on your behalf.

# 9. Carrying-out

## 1. Carrying-out Date

On the final day of the JpGU 2023, May 26th (Fri) 4:00 PM – 5:30 PM.

- Please complete your dismantling by 5:30 PM.

## 2. On use Makuhari Messe designated courier service (domestic)

- You can use Makuhari Messe designated YAMATO Transport (Cash on delivery) .
- Please fill out the required information on the invoice and bring the delivery to the designated location (see the below) on May 26th (Fri). Yamato Transport desk will be set from 4PM on the day.
- Please take free to bring your Invoice at the organizer’s room of the Exhibition Hall 8. Or please receive it at the pick up location at the time of moving out.
- In past years, there have been situations where shipments have not been completed due to problems such as incomplete entries or duplicates. Please check each shipment and prepare an invoice for each package.
- Packages are not expected to arrive until the following day or later. Please note that next day arrival cannot be specified.

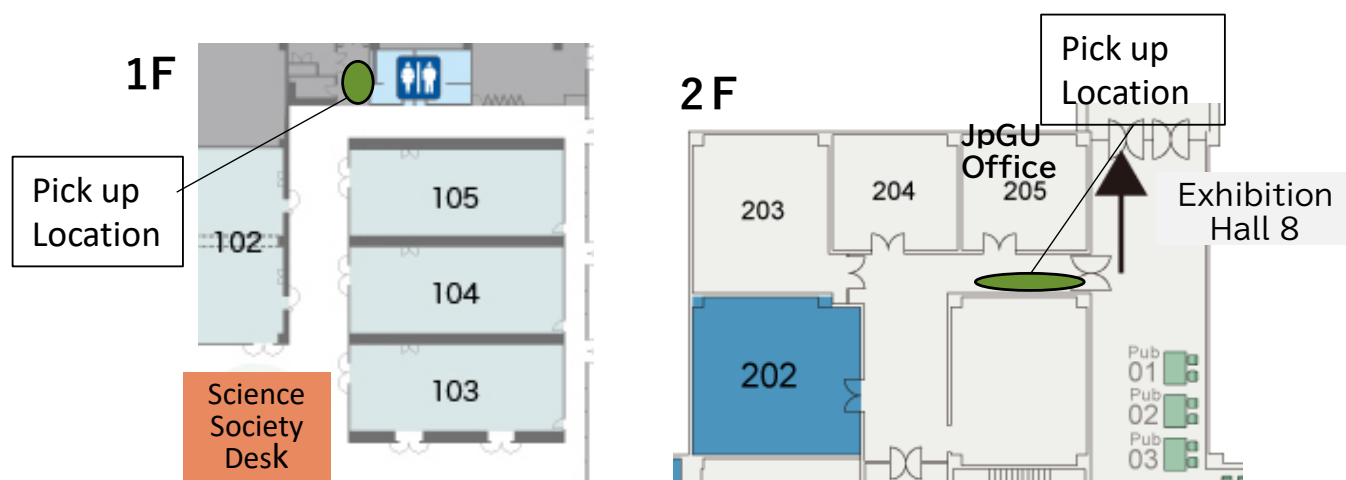

## 3. Shipping by your arrangement

- If you use other courier companies, you will be responsible for your own procedures.
- If you use own vehicles or your own transportation company, please show “Vehicle Pass” at the East Gate 2 before entering the venue.

## 4. Others

- The organizer will not be responsible for any theft or loss on exhibits.
- Please be aware that there will be movement of people during poster presentation in the Exhibition Hall, so please take care to avoid any hazards.



# 10. Carrying in/out Route

## 1. Carrying in/out vehicular passage route

- Please show “Vehicle Pass” issued by the venue (Makuhari Messe) to the security guard at the East Gate 2 which is the vehicle entrance of the venue.
- You need to require your vehicle pass in advance through the on-line system as one of the option items.
- Please follow the directions as below.

1) East Gate 2 ⇒ Carry-in Entrance/Carry-out Exit beside the General Control Center ⇒ North Gate

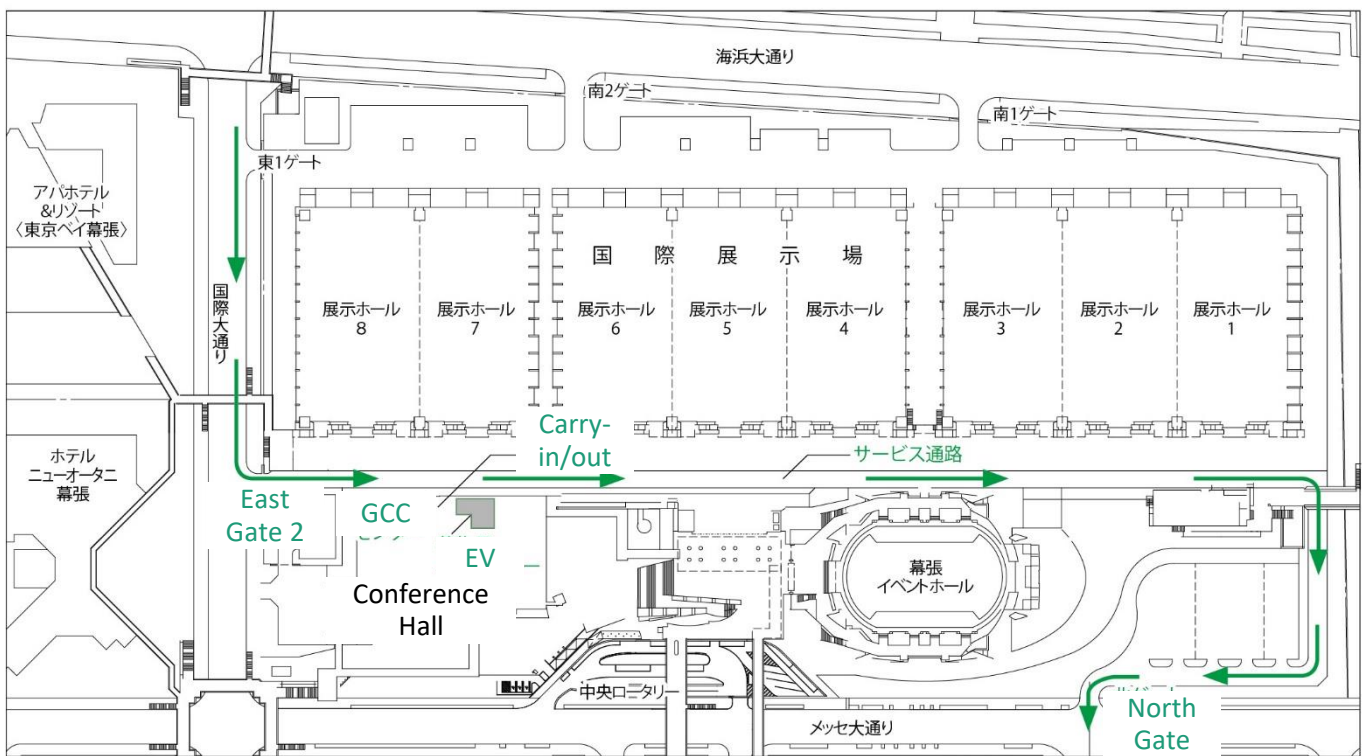

## 2. Carrying in/out in the International Conference Hall

You can use the freight elevators for carrying goods in and out of the second and third floors.

- a) Freight Elevator (Large) 2.35 m (W) x 5.40 m (D) x 2.40 m (H) Maximum load: 3,200kg
- b) Freight Elevator (Small) 2.20 m (W) x 2.80 m (D) x 2.10 m (H) Maximum load: 2,000kg

The protection of floors, walls, doors, and others against damage is required depending on the type of goods.

# 11-1 Important Notes

Exhibitors shall observe the following regulations

## 1. General

- We will make every effort to ensure the security of the venue during the JpGU Meeting. However management cannot assume responsibility for damage arising from natural disaster, fire, theft, loss of property or any other cause. Please make your belongings secured by yourself, such as not to leave your valuables on the empty booth, or to use chains to fix to the booth. Exhibitors are asked to be responsible for all of their belongings and to obtain suitable insurance cover for any valuable items.
- Unfortunately there is no storage space available at the meeting venue.
- We may, due to force majeure, make major changes to the exhibition timetable or, in extreme cases, cancel exhibitions entirely. In such case part of the exhibition fee may be refunded to exhibitors. In no other case shall we be responsible for losses or expenses incurred by exhibitors.
- We reserves the right to refuse to allow any exhibition which is in their view unsuitable for JpGU Meeting.
- Subletting, selling, transferring, or exchanging exhibition space, either in whole or in part, to any third party, including other exhibitors, is prohibited.
- Please abide by the timetable given for carrying-in, showing and carrying-out exhibitions. Please contact us as soon as possible should this not be possible.

## 2. Booth Set up and Dismantling

- Direct work upon or modification to the floors, walls, columns, doors and other structures of the exhibition venue is prohibited. Please be careful not to damage or deface any part of the venue during carrying-in, carrying-out, and show hours.
- Exhibitors are not permitted to erect temporary ceilings or any similar structure. As a general rule the height limit for the highest point of an exhibition is 2.5m. Exhibitors who of necessity wish to exceed this limit are asked to obtain permission to do so from us in advance. We reserves the right to refuse such permission at its discretion.
- Exhibitors who wish to use anchor bolts are requested to contact us in advance. Restoration expenses will be invoiced to the exhibitor. Maximum allowed anchor depth is 80mm. Anchor bolts should not be installed in the pit.
- Maximum allowed load pressure on the exhibition hall floor is 5 t/m<sup>2</sup> (except for the pit). Those with heavy exhibits are asked to contact us in advance.
- Any potentially flammable materials used in exhibitions such as display mountings, carpeting, curtains etc. must be fireproof. Please attach a fireproof tag to all such items.

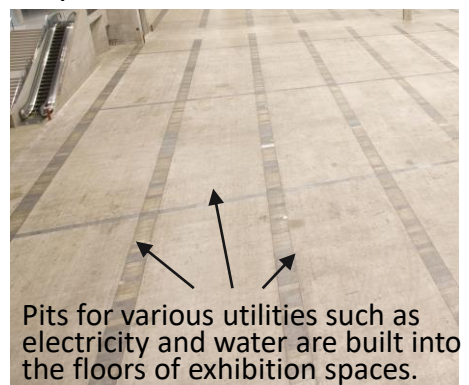

# 11-2 Important Notes

- The Chiba city fire prevention law prohibits smoking, live flames, exposed elements, liquefied petroleum gas or other flammable gases, gasoline, kerosene, flammable oils and other similar hazardous objects and substances.
- Exhibitors are required to remove and suitably dispose of all of their waste and scrap materials.
- As there is no storage space available at the venue, exhibitors are asked to keep empty boxes, packaging materials, stocks etc. within their exhibition booth.
- If either we or exhibition venue staff determine that an exhibit is dangerous or is causing any other problem the exhibitor will be required to immediately take any necessary corrective measures.

### 3. During JpGU Meeting Hours

- Exhibitors are required to keep noise, vibration, smell, smoke etc. to levels which do not interfere with other exhibitors, meeting participants or venue staff.
- Exhibitors should restrict the audio volume from their booth so as not to cause inconvenience to other exhibitors and participants. If complaints are received or noise is deemed to be excessive the we will require the exhibitor in question to reduce the volume. In addition to disrupting the normal progress of the meeting, excessive volume may cause serious problems in an emergency situation.
- Exhibitors are not permitted to use the space outside their booth for presentations or product exhibitions.
- If either we or exhibition venue staff determine that an exhibit is dangerous or is causing any other problem the exhibitor will be required to immediately take any necessary corrective measures.

### 4. Measures to prevent spread of COVID 19 infection

Please observe the guidelines and precautions specified by the organizer and Makuhari Messe.

[JpGU Office]

[https://www.jpгу.org/meeting\\_j2023/for\\_researcher.php#сovid19](https://www.jpгу.org/meeting_j2023/for_researcher.php#сovid19)

[Makuhari Messe]

<https://www.m-messe.co.jp/information/detail/1884>